

# A

A P P E N D I X

## Assemblers, Linkers, and the SPIM Simulator

*James R. Larus*  
Computer Sciences Department  
University of Wisconsin–Madison

*Fear of serious injury cannot alone  
justify suppression of free speech  
and assembly.*

Louis Brandeis  
*Whitney v. California, 1927*

Copyright 1998 Morgan Kaufmann Publishers.  
No portion of this material may be reproduced without permission of the publisher.

A.1	Introduction	A-3
A.2	Assemblers	A-10
A.3	Linkers	A-17
A.4	Loading	A-19
A.5	Memory Usage	A-20
A.6	Procedure Call Convention	A-22
A.7	Exceptions and Interrupts	A-32
A.8	Input and Output	A-36
A.9	SPIM	A-38
A.10	MIPS R2000 Assembly Language	A-49
A.11	Concluding Remarks	A-75
A.12	Key Terms	A-76
A.13	Exercises	A-76

---

## A.1

### Introduction

Encoding instructions as binary numbers is natural and efficient for computers. Humans, however, have a great deal of difficulty understanding and manipulating these numbers. People read and write symbols (words) much better than long sequences of digits. Chapter 3 showed that we need not choose between numbers and words because computer instructions can be represented in many ways. Humans can write and read symbols, and computers can execute the equivalent binary numbers. This appendix describes the process by which a human-readable program is translated into a form that a computer can execute, provides a few hints about writing assembly programs, and explains how to run these programs on SPIM, a simulator that executes MIPS programs. Unix, Windows, and DOS versions of the SPIM simulator are available through [www.mkp.com/cod2e.htm](http://www.mkp.com/cod2e.htm).

*Assembly language* is the symbolic representation of a computer's binary encoding—*machine language*. Assembly language is more readable than machine language because it uses symbols instead of bits. The symbols in assembly language name commonly occurring bit patterns, such as opcodes and register specifiers, so people can read and remember them. In addition, assembly language permits programmers to use *labels* to identify and name particular memory words that hold instructions or data.



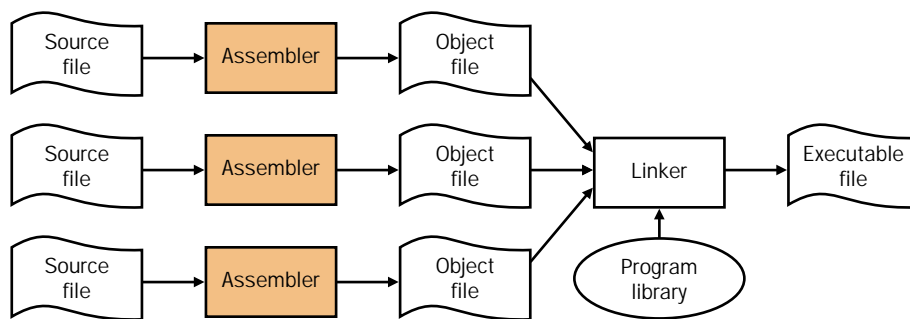

FIGURE A.1 The process that produces an executable file. An assembler translates a file of assembly language into an object file, which is linked with other files and libraries into an executable file.

A tool called an *assembler* translates assembly language into binary instructions. Assemblers provide a friendlier representation than a computer's 0s and 1s that simplifies writing and reading programs. Symbolic names for operations and locations are one facet of this representation. Another facet is programming facilities that increase a program's clarity. For example, *macros*, discussed in section A.2, enable a programmer to extend the assembly language by defining new operations.

An assembler reads a single assembly language *source file* and produces an *object file* containing machine instructions and bookkeeping information that helps combine several object files into a program. Figure A.1 illustrates how a program is built. Most programs consist of several files—also called *modules*—that are written, compiled, and assembled independently. A program may also use prewritten routines supplied in a *program library*. A module typically contains *references* to subroutines and data defined in other modules and in libraries. The code in a module cannot be executed when it contains *unresolved references* to labels in other object files or libraries. Another tool, called a *linker*, combines a collection of object and library files into an *executable file*, which a computer can run.

To see the advantage of assembly language, consider the following sequence of figures, all of which contain a short subroutine that computes and prints the sum of the squares of integers from 0 to 100. Figure A.2 shows the machine language that a MIPS computer executes. With considerable effort, you could use the opcode and instruction format tables in Chapters 3 and 4 to translate the instructions into a symbolic program similar to Figure A.3. This form of the routine is much easier to read because operations and operands are written with symbols, rather than with bit patterns. However, this assembly

```

001001111011110111111111111100000
101011111011111110000000000010100
10101111101001000000000000100000
10101111101001010000000000100100
1010111110100000000000000011000
1010111110100000000000000011100
1000111110101110000000000011100
1000111110111000000000000011000
0000001110011100000000000011001
0010010111001000000000000000001
0010100100000010000000001100101
1010111110101000000000000011100
00000000000000000011110000010010
00000011000011111100100000100001
0001010000100000111111111110111
1010111110111001000000000011000
0011110000001000001000000000000
1000111110100101000000000011000
0000110000010000000000001101100
00100100100001000000010000110000
1000111110111111000000000010100
00100111101111010000000000100000
000000111110000000000000001000
000000000000000000100000100001

```

FIGURE A.2 MIPS machine language code for a routine to compute and print the sum of the squares of integers between 0 and 100.

language is still difficult to follow because memory locations are named by their address, rather than by a symbolic label.

Figure A.4 shows assembly language that labels memory addresses with mnemonic names. Most programmers prefer to read and write this form. Names that begin with a period, for example `.data` and `.globl`, are *assembler directives* that tell the assembler how to translate a program but do not produce machine instructions. Names followed by a colon, such as `str` or `main`, are labels that name the next memory location. This program is as readable as most assembly language programs (except for a glaring lack of comments), but it is still difficult to follow because many simple operations are required to accomplish simple tasks and because assembly language's lack of control flow constructs provides few hints about the program's operation.

By contrast, the C routine in Figure A.5 is both shorter and clearer since variables have mnemonic names and the loop is explicit rather than constructed with branches. (If you are unfamiliar with C, you may wish to look at Web Extension II at [www.mkp.com/cod2e.htm](http://www.mkp.com/cod2e.htm).) In fact, the C routine is the only one that we wrote. The other forms of the program were produced by a C compiler and assembler.



```

addi u $29, $29, -32
sw     $31, 20($29)
sw     $4, 32($29)
sw     $5, 36($29)
sw     $0, 24($29)
sw     $0, 28($29)
lw     $14, 28($29)
lw     $24, 24($29)
mul tu $14, $14
addi u $8, $14, 1
sl ti  $1, $8, 101
sw     $8, 28($29)
mfl o  $15
addu   $25, $24, $15
bne    $1, $0, -9
sw     $25, 24($29)
lui    $4, 4096
lw     $5, 24($29)
jal    1048 812
addi u $4, $4, 1072
lw     $31, 20($29)
addi u $29, $29, 32
jr     $31
move   $2, $0

```

FIGURE A.3 The same routine written in assembly language. However, the code for the routine does not label registers or memory locations nor include comments.

In general, assembly language plays two roles (see Figure A.6). The first role is the output language of compilers. A *compiler* translates a program written in a *high-level language* (such as C or Pascal) into an equivalent program in machine or assembly language. The high-level language is called the *source language*, and the compiler's output is its *target language*.

Assembly language's other role is as a language in which to write programs. This role used to be the dominant one. Today, however, because of larger main memories and better compilers, most programmers write in a high-level language and rarely, if ever, see the instructions that a computer executes. Nevertheless, assembly language is still important to write programs in which speed or size are critical or to exploit hardware features that have no analogues in high-level languages.

Although this appendix focuses on MIPS assembly language, assembly programming on most other machines is very similar. The additional instructions and address modes in CISC machines, such as the VAX (see Web Extension III at [www.mkp.com/cod2e.htm](http://www.mkp.com/cod2e.htm)), can make assembly programs shorter but do not change the process of assembling a program or provide assembly language with the advantages of high-level languages such as type-checking and structured control flow.



```

        .text
        .align 2
        .globl main
main:
        subu    $sp, $sp, 32
        sw     $ra, 20($sp)
        sd     $a0, 32($sp)
        sw     $0, 24($sp)
        sw     $0, 28($sp)
loop:
        lw     $t6, 28($sp)
        mul   $t7, $t6, $t6
        lw     $t8, 24($sp)
        addu  $t9, $t8, $t7
        sw     $t9, 24($sp)
        addu  $t0, $t6, 1
        sw     $t0, 28($sp)
        ble   $t0, 100, loop
        la    $a0, str
        lw    $a1, 24($sp)
        jal   printf
        move  $v0, $0
        lw    $ra, 20($sp)
        addu  $sp, $sp, 32
        j     $ra

        .data
        .align 0
str:
        .asciiz "The sum from 0 .. 100 is %d\n"

```

FIGURE A.4 The same routine written in assembly language with labels, but no comments. The commands that start with periods are assembler directives (see pages A-51–A-53). `.text` indicates that succeeding lines contain instructions. `.data` indicates that they contain data. `.align n` indicates that the items on the succeeding lines should be aligned on a  $2^n$  byte boundary. Hence, `.align 2` means the next item should be on a word boundary. `.globl main` declares that `main` is a global symbol that should be visible to code stored in other files. Finally, `.asciiz` stores a null-terminated string in memory.

## When to Use Assembly Language

The primary reason to program in assembly language, as opposed to an available high-level language, is that the speed or size of a program is critically important. For example, consider a computer that controls a piece of machinery, such as a car's brakes. A computer that is incorporated in another device, such as a car, is called an *embedded computer*. This type of computer needs to respond rapidly and predictably to events in the outside world. Because a

```

#include <stdio.h>

int
main (int argc, char *argv[])
{
    int i;
    int sum = 0;

    for (i = 0; i <= 100; i = i + 1) sum = sum + i * i;
    printf ("The sum from 0 .. 100 is %d\n", sum);
}

```

FIGURE A.5 The routine written in the C programming language.

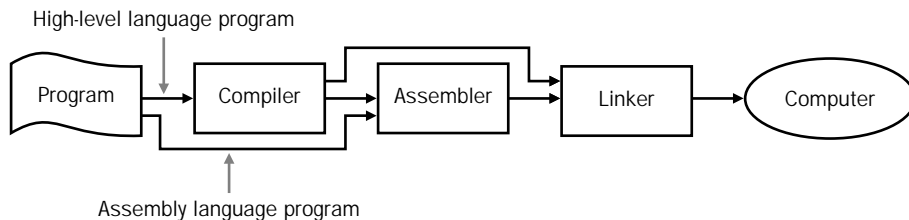

FIGURE A.6 Assembly language either is written by a programmer or is the output of a compiler.

compiler introduces uncertainty about the time cost of operations, programmers may find it difficult to ensure that a high-level language program responds within a definite time interval—say, 1 millisecond after a sensor detects that a tire is skidding. An assembly language programmer, on the other hand, has tight control over which instructions execute. In addition, in embedded applications, reducing a program's size, so that it fits in fewer memory chips, reduces the cost of the embedded computer.

A hybrid approach, in which most of a program is written in a high-level language and time-critical sections are written in assembly language, builds on the strengths of both languages. Programs typically spend most of their time executing a small fraction of the program's source code. This observation is just the principle of locality that underlies caches (see section 7.2 in Chapter 7).

Program profiling measures where a program spends its time and can find the time-critical parts of a program. In many cases, this portion of the program can be made faster with better data structures or algorithms. Sometimes, however, significant performance improvements only come from recoding a critical portion of a program in assembly language.

This improvement is not necessarily an indication that the high-level language's compiler has failed. Compilers typically are better than programmers at producing uniformly high-quality machine code across an entire program. Programmers, however, understand a program's algorithms and behavior at a deeper level than a compiler and can expend considerable effort and ingenuity improving small sections of the program. In particular, programmers often consider several procedures simultaneously while writing their code. Compilers typically compile each procedure in isolation and must follow strict conventions governing the use of registers at procedure boundaries. By retaining commonly used values in registers, even across procedure boundaries, programmers can make a program run faster.

Another major advantage of assembly language is the ability to exploit specialized instructions, for example, string copy or pattern-matching instructions. Compilers, in most cases, cannot determine that a program loop can be replaced by a single instruction. However, the programmer who wrote the loop can replace it easily with a single instruction.

In the future, a programmer's advantage over a compiler is likely to become increasingly difficult to maintain as compilation techniques improve and machines' pipelines increase in complexity (Chapter 6).

The final reason to use assembly language is that no high-level language is available on a particular computer. Many older or specialized computers do not have a compiler, so a programmer's only alternative is assembly language.

## Drawbacks of Assembly Language

Assembly language has many disadvantages that strongly argue against its widespread use. Perhaps its major disadvantage is that programs written in assembly language are inherently machine-specific and must be totally rewritten to run on another computer architecture. The rapid evolution of computers discussed in Chapter 1 means that architectures become obsolete. An assembly language program remains tightly bound to its original architecture, even after the computer is eclipsed by new, faster, and more cost-effective machines.

Another disadvantage is that assembly language programs are longer than the equivalent programs written in a high-level language. For example, the C program in Figure A.5 is 11 lines long, while the assembly program in Figure A.4 is 31 lines long. In more complex programs, the ratio of assembly to high-level language (its *expansion factor*) can be much larger than the factor of three in this example. Unfortunately, empirical studies have shown that programmers write roughly the same number of lines of code per day in assembly as in high-level languages. This means that programmers are roughly  $x$  times more productive in a high-level language, where  $x$  is the assembly language expansion factor.



To compound the problem, longer programs are more difficult to read and understand and they contain more bugs. Assembly language exacerbates the problem because of its complete lack of structure. Common programming idioms, such as *if-then* statements and loops, must be built from branches and jumps. The resulting programs are hard to read because the reader must reconstruct every higher-level construct from its pieces and each instance of a statement may be slightly different. For example, look at Figure A.4 and answer these questions: What type of loop is used? What are its lower and upper bounds?

**Elaboration:** Compilers can produce machine language directly instead of relying on an assembler. These compilers typically execute much faster than those that invoke an assembler as part of compilation. However, a compiler that generates machine language must perform many tasks that an assembler normally handles, such as resolving addresses and encoding instructions as binary numbers. The trade-off is between compilation speed and compiler simplicity.

**Elaboration:** Despite these considerations, some embedded applications are written in a high-level language. Many of these applications are large and complex programs that must be extremely reliable. Assembly language programs are longer and more difficult to write and read than high-level language programs. This greatly increases the cost of writing an assembly language program and makes it extremely difficult to verify the correctness of this type of program. In fact, these considerations led the Department of Defense, which pays for many complex embedded systems, to develop Ada, a new high-level language for writing embedded systems.

## A.2

### Assemblers

An assembler translates a file of assembly language statements into a file of binary machine instructions and binary data. The translation process has two major parts. The first step is to find memory locations with labels so the relationship between symbolic names and addresses is known when instructions are translated. The second step is to translate each assembly statement by combining the numeric equivalents of opcodes, register specifiers, and labels into a legal instruction. As shown in Figure A.1, the assembler produces an output file, called an *object file*, which contains the machine instructions, data, and bookkeeping information.

An object file typically cannot be executed because it references procedures or data in other files. A label is *external* (also called *global*) if the labeled object can be referenced from files other than the one in which it is defined. A label is *local* if the object can be used only within the file in which it is defined. In most assemblers, labels are local by default and must be explicitly declared global. Subroutines and global variables require external labels since they are referenced from many files in a program. Local labels hide names that should not be visible to other modules—for example, static functions in C, which can only be called by other functions in the same file. In addition, compiler-generated names—for example, a name for the instruction at the beginning of a loop—are local so the compiler need not produce unique names in every file.

### Local and Global Labels

#### Example

Consider the program in Figure A.4 on page A-7. The subroutine has an external (global) label `main`. It also contains two local labels—`loop` and `str`—that are only visible with this assembly language file. Finally, the routine also contains an unresolved reference to an external label `printf`, which is the library routine that prints values. Which labels in Figure A.4 could be referenced from another file?

#### Answer

Only global labels are visible outside of a file, so the only label that could be referenced from another file is `main`.

Since the assembler processes each file in a program individually and in isolation, it only knows the addresses of local labels. The assembler depends on another tool, the linker, to combine a collection of object files and libraries into an executable file by resolving external labels. The assembler assists the linker by providing lists of labels and unresolved references.

However, even local labels present an interesting challenge to an assembler. Unlike names in most high-level languages, assembly labels may be used before they are defined. In the example, in Figure A.4, the label `str` is used by the `la` instruction before it is defined. The possibility of a *forward reference*, like this one, forces an assembler to translate a program in two steps: first find all labels and then produce instructions. In the example, when the assembler sees the `la` instruction, it does not know where the word labeled `str` is located or even whether `str` labels an instruction or datum.

An assembler's first pass reads each line of an assembly file and breaks it into its component pieces. These pieces, which are called *lexemes*, are individual words, numbers, and punctuation characters. For example, the line

```
bl e $t0, 100, l oop
```

contains 6 lexemes: the opcode `bl e`, the register specifier `$t0`, a comma, the number `100`, a comma, and the symbol `l oop`.

If a line begins with a label, the assembler records in its *symbol table* the name of the label and the address of the memory word that the instruction occupies. The assembler then calculates how many words of memory the instruction on the current line will occupy. By keeping track of the instructions' sizes, the assembler can determine where the next instruction goes. To compute the size of a variable-length instruction, like those on the VAX, an assembler has to examine it in detail. Fixed-length instructions, like those on MIPS, on the other hand, require only a cursory examination. The assembler performs a similar calculation to compute the space required for data statements. When the assembler reaches the end of an assembly file, the symbol table records the location of each label defined in the file.

The assembler uses the information in the symbol table during a second pass over the file, which actually produces machine code. The assembler again examines each line in the file. If the line contains an instruction, the assembler combines the binary representations of its opcode and operands (register specifiers or memory address) into a legal instruction. The process is similar to the one used in section 3.4 in Chapter 3. Instructions and data words that reference an external symbol defined in another file cannot be completely assembled (they are unresolved) since the symbol's address is not in the symbol table. An assembler does not complain about unresolved references since the corresponding label is likely to be defined in another file.

### The Big Picture

Assembly language is a programming language. Its principal difference from high-level languages such as BASIC, Java, and C is that assembly language provides only a few, simple types of data and control flow. Assembly language programs do not specify the type of value held in a variable. Instead, a programmer must apply the appropriate operations (e.g., integer or floating-point addition) to a value. In addition, in assembly language, programs must implement all control flow with *go tos*. Both factors make assembly language programming for any machine—MIPS or 80x86—more difficult and error-prone than writing in a high-level language.

**Elaboration:** If an assembler's speed is important, this two-step process can be done in one pass over the assembly file with a technique known as *backpatching*. In its pass over the file, the assembler builds a (possibly incomplete) binary representation of every instruction. If the instruction references a label that has not yet been defined, the assembler records the label and instruction in a table. When a label is defined, the assembler consults this table to find all instructions that contain a forward reference to the label. The assembler goes back and corrects their binary representation to incorporate the address of the label. Backpatching speeds assembly because the assembler only reads its input once. However, it requires an assembler to hold the entire binary representation of a program in memory so instructions can be backpatched. This requirement can limit the size of programs that can be assembled.

## Object File Format

Assemblers produce object files. An object file on Unix contains six distinct sections (see Figure A.7):

- The *object file header* describes the size and position of the other pieces of the file.
- The *text segment* contains the machine language code for routines in the source file. These routines may be unexecutable because of unresolved references.
- The *data segment* contains a binary representation of the data in the source file. The data also may be incomplete because of unresolved references to labels in other files.
- The *relocation information* identifies instructions and data words that depend on absolute addresses. These references must change if portions of the program are moved in memory.
- The *symbol table* associates addresses with external labels in the source file and lists unresolved references.
- The *debugging information* contains a concise description of the way in which the program was compiled, so a debugger can find which instruction addresses correspond to lines in a source file and print the data structures in readable form.

Object file header	Text segment	Data segment	Relocation information	Symbol table	Debugging information
--------------------	--------------	--------------	------------------------	--------------	-----------------------

FIGURE A.7 Object file. A Unix assembler produces an object file with six distinct sections.

The assembler produces an object file that contains a binary representation of the program and data and additional information to help link pieces of a program. This relocation information is necessary because the assembler does not know which memory locations a procedure or piece of data will occupy after it is linked with the rest of the program. Procedures and data from a file are stored in a contiguous piece of memory, but the assembler does not know where this memory will be located. The assembler also passes some symbol table entries to the linker. In particular, the assembler must record which external symbols are defined in a file and what unresolved references occur in a file.

**Elaboration:** For convenience, assemblers assume each file starts at the same address (for example, location 0) with the expectation that the linker will *relocate* the code and data when they are assigned locations in memory. The assembler produces *relocation information*, which contains an entry describing each instruction or data word in the file that references an absolute address. On MIPS, only the subroutine call, load, and store instructions reference absolute addresses. Instructions that use PC-relative addressing, such as branches, need not be relocated.

## Additional Facilities

Assemblers provide a variety of convenience features that help make assembler programs short and easier to write, but do not fundamentally change assembly language. For example, *data layout directives* allow a programmer to describe data in a more concise and natural manner than its binary representation.

In Figure A.4, the directive

```
.asciiz "The sum from 0 .. 100 is %d\n"
```

stores characters from the string in memory. Contrast this line with the alternative of writing each character as its ASCII value (Figure 3.15 in Chapter 3 describes the ASCII encoding for characters):

```
.byte 84, 104, 101, 32, 115, 117, 109, 32  
.byte 102, 114, 111, 109, 32, 48, 32, 46  
.byte 46, 32, 49, 48, 48, 32, 105, 115  
.byte 32, 37, 100, 10, 0
```

The `.asciiz` directive is easier to read because it represents characters as letters, not binary numbers. An assembler can translate characters to their binary representation much faster and more accurately than a human. Data layout directives specify data in a human-readable form that the assembler translates to binary. Other layout directives are described in section A.10 on pages A-51–A-53.

## String Directive

## Example

Define the sequence of bytes produced by this directive:

```
.asciiz "The quick brown fox jumps over the lazy dog"
```

## Answer

```
.byte 84, 104, 101, 32, 113, 117, 105, 99
.byte 107, 32, 98, 114, 111, 119, 110, 32
.byte 102, 111, 120, 32, 106, 117, 109, 112
.byte 115, 32, 111, 118, 101, 114, 32, 116
.byte 104, 101, 32, 108, 97, 122, 121, 32
.byte 100, 111, 103, 0
```

*Macros* are a pattern-matching and replacement facility that provide a simple mechanism to name a frequently used sequence of instructions. Instead of repeatedly typing the same instructions every time they are used, a programmer invokes the macro and the assembler replaces the macro call with the corresponding sequence of instructions. Macros, like subroutines, permit a programmer to create and name a new abstraction for a common operation. Unlike subroutines, however, macros do not cause a subroutine call and return when the program runs since a macro call is replaced by the macro's body when the program is assembled. After this replacement, the resulting assembly is indistinguishable from the equivalent program written without macros.

## Macros

## Example

As an example, suppose that a programmer needs to print many numbers. The library routine `printf` accepts a format string and one or more values to print as its arguments. A programmer could print the integer in register \$7 with the following instructions:

```
.data
int_str: .asciiz "%d"
.text
la      $a0, int_str # Load string address
                        # into first arg
mov     $a1, $7      # Load value into
                        # second arg
jal     printf       # Call the printf routine
```

The `.data` directive tells the assembler to store the string in the program's data segment, and the `.text` directive tells the assembler to store the instructions in its text segment.

However, printing many numbers in this fashion is tedious and produces a verbose program that is difficult to understand. An alternative is to introduce a macro, `print_int`, to print an integer:

```

        .data
int_str: .asciiz "%d"
        .text
        .macro print_int($arg)
        la      $a0, int_str # Load string address into
                                # first arg
        mov     $a1, $arg    # Load macro's parameter
                                # ($arg) into second arg
        jal     printf      # Call the printf routine
        .end_macro
print_int($7)

```

The macro has a *formal parameter*, `$arg`, that names the argument to the macro. When the macro is expanded, the argument from a call is substituted for the formal parameter throughout the macro's body. Then the assembler replaces the call with the macro's newly expanded body. In the first call on `print_int`, the argument is `$7`, so the macro expands to the code

```

        la  $a0, int_str
        mov $a1, $7
        jal printf

```

In a second call on `print_int`, say, `print_int($t0)`, the argument is `$t0`, so the macro expands to

```

        la  $a0, int_str
        mov $a1, $t0
        jal printf

```

What does the call `print_int($a0)` expand to?

Answer

```

        la  $a0, int_str
        mov $a1, $a0
        jal printf

```

This example illustrates a drawback of macros. A programmer who uses this macro must be aware that `print_int` uses register `$a0` and so cannot correctly print the value in that register.

### Hardware Software Interface

Some assemblers also implement *pseudoinstructions*, which are instructions provided by an assembler but not implemented in hardware. Chapter 3 contains many examples of how the MIPS assembler synthesizes pseudoinstructions and addressing modes from the spartan MIPS hardware instruction set. For example, section 3.5 in Chapter 3 describes how the assembler synthesizes the `blt` instruction from two other instructions: `slt` and `bne`. By extending the instruction set, the MIPS assembler makes assembly language programming easier without complicating the hardware. Many pseudoinstructions could also be simulated with macros, but the MIPS assembler can generate better code for these instructions because it can use a dedicated register (`$at`) and is able to optimize the generated code.

**Elaboration:** Assemblers *conditionally assemble* pieces of code, which permits a programmer to include or exclude groups of instructions when a program is assembled. This feature is particularly useful when several versions of a program differ by a small amount. Rather than keep these programs in separate files—which greatly complicates fixing bugs in the common code—programmers typically merge the versions into a single file. Code particular to one version is conditionally assembled, so it can be excluded when other versions of the program are assembled.

If macros and conditional assembly are useful, why do assemblers for Unix systems rarely, if ever, provide them? One reason is that most programmers on these systems write programs in higher-level languages like C. Most of the assembly code is produced by compilers, which find it more convenient to repeat code rather than define macros. Another reason is that other tools on Unix—such as `cpp`, the C preprocessor, or `m4`, a general macro processor—can provide macros and conditional assembly for assembly language programs.

## A.3

### Linkers

*Separate compilation* permits a program to be split into pieces that are stored in different files. Each file contains a logically related collection of subroutines and data structures that form a *module* in a larger program. A file can be compiled and assembled independently of other files, so changes to one module do not require recompiling the entire program. As we discussed above, separate compilation necessitates the additional step of linking to combine object files from separate modules and fix their unresolved references.



The tool that merges these files is the *linker* (see Figure A.8). It performs three tasks:

- Searches the program libraries to find library routines used by the program
- Determines the memory locations that code from each module will occupy and relocates its instructions by adjusting absolute references
- Resolves references among files

A linker's first task is to ensure that a program contains no undefined labels. The linker matches the external symbols and unresolved references from a program's files. An external symbol in one file resolves a reference from another file if both refer to a label with the same name. Unmatched references mean a symbol was used, but not defined anywhere in the program.

Unresolved references at this stage in the linking process do not necessarily mean a programmer made a mistake. The program could have referenced a library routine whose code was not in the object files passed to the linker. After matching symbols in the program, the linker searches the system's program libraries to find predefined subroutines and data structures that the program

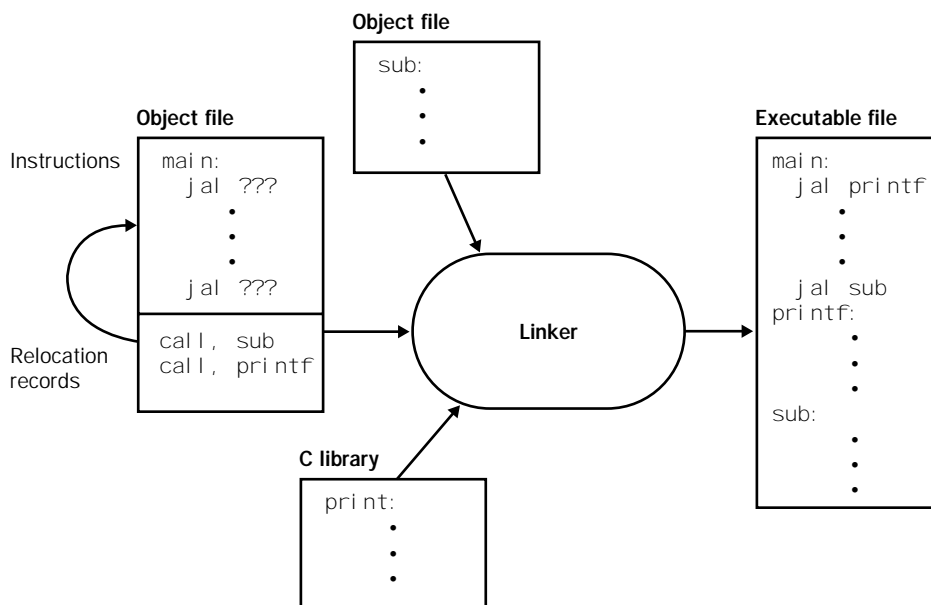

FIGURE A.8 The linker searches a collection of object files and program libraries to find non-local routines used in a program, combines them into a single executable file, and resolves references between routines in different files.

references. The basic libraries contain routines that read and write data, allocate and deallocate memory, and perform numeric operations. Other libraries contain routines to access a database or manipulate terminal windows. A program that references an unresolved symbol that is not in any library is erroneous and cannot be linked. When the program uses a library routine, the linker extracts the routine's code from the library and incorporates it into the program text segment. This new routine, in turn, may depend on other library routines, so the linker continues to fetch other library routines until no external references are unresolved or a routine cannot be found.

If all external references are resolved, the linker next determines the memory locations that each module will occupy. Since the files were assembled in isolation, the assembler could not know where a module's instructions or data will be placed relative to other modules. When the linker places a module in memory, all absolute references must be *relocated* to reflect its true location. Since the linker has relocation information that identifies all relocatable references, it can efficiently find and backpatch these references.

The linker produces an executable file that can run on a computer. Typically, this file has the same format as an object file, except that it contains no unresolved references or relocation information.

## A.4

### Loading

A program that links without an error can be run. Before being run, the program resides in a file on secondary storage, such as a disk. On Unix systems, the operating system kernel brings a program into memory and starts it running. To start a program, the operating system performs the following steps:

1. Reads the executable file's header to determine the size of the text and data segments.
2. Creates a new address space for the program. This address space is large enough to hold the text and data segments, along with a stack segment (see section A.5).
3. Copies instructions and data from the executable file into the new address space.
4. Copies arguments passed to the program onto the stack.
5. Initializes the machine registers. In general, most registers are cleared, but the stack pointer must be assigned the address of the first free stack location (see section A.5).

6. Jumps to a start-up routine that copies the program's arguments from the stack to registers and calls the program's `main` routine. If the `main` routine returns, the start-up routine terminates the program with the exit system call.

## A.5

### Memory Usage

The next few sections elaborate the description of the MIPS architecture presented earlier in the book. Earlier chapters focused primarily on hardware and its relationship with low-level software. These sections focus primarily on how assembly language programmers use MIPS hardware. These sections describe a set of conventions followed on many MIPS systems. For the most part, the hardware does not impose these conventions. Instead, they represent an agreement among programmers to follow the same set of rules so that software written by different people can work together and make effective use of MIPS hardware.

Systems based on MIPS processors typically divide memory into three parts (see Figure A.9). The first part, near the bottom of the address space (starting at address  $400000_{\text{hex}}$ ), is the *text segment*, which holds the program's instructions.

The second part, above the text segment, is the *data segment*, which is further divided into two parts. *Static data* (starting at address  $10000000_{\text{hex}}$ ) contains objects whose size is known to the compiler and whose lifetime—the interval during which a program can access them—is the program's entire execution. For example, in C, global variables are statically allocated since they can be referenced anytime during a program's execution. The linker both assigns static objects to locations in the data segment and resolves references to these objects.

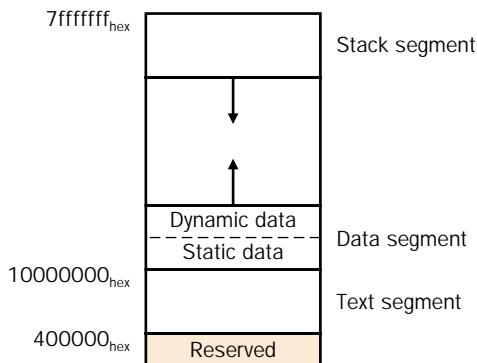

FIGURE A.9 Layout of memory.

Immediately above static data is *dynamic data*. This data, as its name implies, is allocated by the program as it executes. In C programs, the `malloc` library routine finds and returns a new block of memory. Since a compiler cannot predict how much memory a program will allocate, the operating system expands the dynamic data area to meet demand. As the upward arrow in the figure indicates, `malloc` expands the dynamic area with the `sbrk` system call, which causes the operating system to add more pages to the program's virtual address space (see section 7.3 in Chapter 7) immediately above the dynamic data segment.

The third part, the program *stack segment*, resides at the top of the virtual address space (starting at address `7fffffffhex`). Like dynamic data, the maximum size of a program's stack is not known in advance. As the program pushes values on the stack, the operating system expands the stack segment down, towards the data segment.

This three-part division of memory is not the only possible one. However, it has two important characteristics: the two dynamically expandable segments are as far apart as possible, and they can grow to use a program's entire address space.

### Hardware Software Interface

Because the data segment begins far above the program at address `10000000hex`, load and store instructions cannot directly reference data objects with their 16-bit offset fields (see section 3.4 in Chapter 3). For example, to load the word in the data segment at address `10008000hex` into register `$v0` requires two instructions:

```
l ui  $s0, 0x1000 # 0x1000 means 1000 base 16 or 4096 base 10
l w   $v0, 0x8000($s0) # 0x10000000 + 0x8000 = 0x10008000
```

(The `0x` before a number means that it is a hexadecimal value. For example, `0x8000` is `8000hex` or `32,768ten`.)

To avoid repeating the `l ui` instruction at every load and store, MIPS systems typically dedicate a register (`$gp`) as a *global pointer* to the static data segment. This register contains address `10008000hex`, so load and store instructions can use their signed 16-bit offset fields to access the first 64 KB of the static data segment. With this global pointer, we can rewrite the example as a single instruction:

```
l w $v0, 0($gp)
```

Of course, a global pointer register makes addressing locations `10000000hex`–`10010000hex` faster than other heap locations. The MIPS compiler usually stores *global variables* in this area because these variables have fixed locations and fit better than other global data, such as arrays.

## A.6

## Procedure Call Convention

Conventions governing the use of registers are necessary when procedures in a program are compiled separately. To compile a particular procedure, a compiler must know which registers it may use and which registers are reserved for other procedures. Rules for using registers are called *register use* or *procedure call conventions*. As the name implies, these rules are, for the most part, conventions followed by software rather than rules enforced by hardware. However, most compilers and programmers try very hard to follow these conventions because violating them causes insidious bugs.

The calling convention described in this section is the one used by the gcc compiler. The native MIPS compiler uses a more complex convention that is slightly faster.

The MIPS CPU contains 32 general-purpose registers that are numbered 0–31. Register \$0 always contains the hardwired value 0.

- Registers \$at (1), \$k0 (26), and \$k1 (27) are reserved for the assembler and operating system and should not be used by user programs or compilers.
- Registers \$a0–\$a3 (4–7) are used to pass the first four arguments to routines (remaining arguments are passed on the stack). Registers \$v0 and \$v1 (2, 3) are used to return values from functions.
- Registers \$t0–\$t9 (8–15, 24, 25) are caller-saved registers that are used to hold temporary quantities that need not be preserved across calls (see section 3.6 in Chapter 3).
- Registers \$s0–\$s7 (16–23) are callee-saved registers that hold long-lived values that should be preserved across calls.
- Register \$gp (28) is a global pointer that points to the middle of a 64K block of memory in the static data segment.
- Register \$sp (29) is the stack pointer, which points to the first free location on the stack. Register \$fp (30) is the frame pointer. The `jal` instruction writes register \$ra (31), the return address from a procedure call. These two registers are explained in the next section.

The two-letter abbreviations and names for these registers—for example \$sp for the stack pointer—reflect the registers’ intended uses in the procedure call convention. In describing this convention, we will use the names instead of register numbers. The table in Figure A.10 lists the registers and describes their intended uses.

Register name	Number	Usage
\$zero	0	constant 0
\$at	1	reserved for assembler
\$v0	2	expression evaluation and results of a function
\$v1	3	expression evaluation and results of a function
\$a0	4	argument 1
\$a1	5	argument 2
\$a2	6	argument 3
\$a3	7	argument 4
\$t0	8	temporary (not preserved across call)
\$t1	9	temporary (not preserved across call)
\$t2	10	temporary (not preserved across call)
\$t3	11	temporary (not preserved across call)
\$t4	12	temporary (not preserved across call)
\$t5	13	temporary (not preserved across call)
\$t6	14	temporary (not preserved across call)
\$t7	15	temporary (not preserved across call)
\$s0	16	saved temporary (preserved across call)
\$s1	17	saved temporary (preserved across call)
\$s2	18	saved temporary (preserved across call)
\$s3	19	saved temporary (preserved across call)
\$s4	20	saved temporary (preserved across call)
\$s5	21	saved temporary (preserved across call)
\$s6	22	saved temporary (preserved across call)
\$t7	23	saved temporary (preserved across call)
\$t8	24	temporary (not preserved across call)
\$t9	25	temporary (not preserved across call)
\$k0	26	reserved for OS kernel
\$k1	27	reserved for OS kernel
\$gp	28	pointer to global area
\$sp	29	stack pointer
\$fp	30	frame pointer
\$ra	31	return address (used by function call)

FIGURE A.10 MIPS registers and usage convention.

## Procedure Calls

This section describes the steps that occur when one procedure (the *caller*) invokes another procedure (the *callee*). Programmers who write in a high-level language (like C or Pascal) never see the details of how one procedure calls another because the compiler takes care of this low-level bookkeeping. However, assembly language programmers must explicitly implement every procedure call and return.

Most of the bookkeeping associated with a call is centered around a block of memory called a *procedure call frame*. This memory is used for a variety of purposes:

- To hold values passed to a procedure as arguments
- To save registers that a procedure may modify, but which the procedure's caller does not want changed
- To provide space for variables local to a procedure

In most programming languages, procedure calls and returns follow a strict last-in, first-out (LIFO) order, so this memory can be allocated and deallocated on a stack, which is why these blocks of memory are sometimes called *stack frames*.

Figure A.11 shows a typical stack frame. The frame consists of the memory between the frame pointer (`$fp`), which points to the first word of the frame, and the stack pointer (`$sp`), which points to the last word the frame. The stack grows down from higher memory addresses, so the frame pointer points above the stack pointer. The executing procedure uses the frame pointer to quickly access values in its stack frame. For example, an argument in the stack frame can be loaded into register `$v0` with the instruction

```
lw $v0, 0($fp)
```

A stack frame may be built in many different ways; however, the caller and callee must agree on the sequence of steps. The steps below describe the calling convention used on most MIPS machines. This convention comes into play at three points during a procedure call: immediately before the caller invokes the callee, just as the callee starts executing, and immediately before the callee returns to the caller. In the first part, the caller puts the procedure call arguments in standard places and invokes the callee to do the following:

1. **Pass arguments.** By convention, the first four arguments are passed in registers `$a0–$a3`. Any remaining arguments are pushed on the stack and appear at the beginning of the called procedure's stack frame.
2. **Save caller-saved registers.** The called procedure can use these registers (`$a0–$a3` and `$t0–$t9`) without first saving their value. If the caller expects to use one of these registers after a call, it must save its value before the call.
3. **Execute a `jal` instruction** (see section 3.6 of Chapter 3), which jumps to the callee's first instruction and saves the return address in register `$ra`.

Before a called routine starts running, it must take the following steps to set up its stack frame:

1. **Allocate memory for the frame** by subtracting the frame's size from the stack pointer.

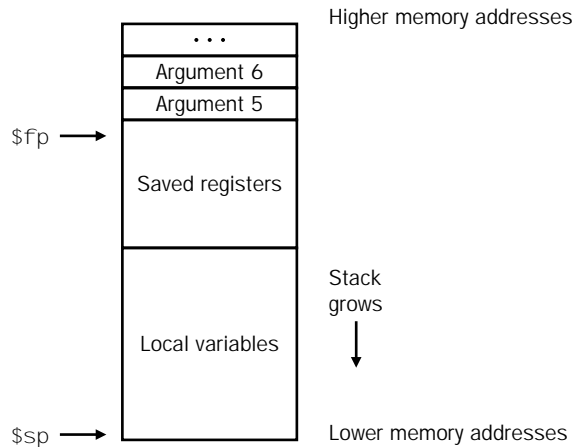

FIGURE A.11 Layout of a stack frame. The frame pointer ( $\$fp$ ) points to the first word in the currently executing procedure's stack frame. The stack pointer ( $\$sp$ ) points to the last word of frame. The first four arguments are passed in registers, so the fifth argument is the first one stored on the stack.

2. Save callee-saved registers in the frame. A callee must save the values in these registers ( $\$s0$ – $\$s7$ ,  $\$fp$ , and  $\$ra$ ) before altering them since the caller expects to find these registers unchanged after the call. Register  $\$fp$  is saved by every procedure that allocates a new stack frame. However, register  $\$ra$  only needs to be saved if the callee itself makes a call. The other callee-saved registers that are used also must be saved.
3. Establish the frame pointer by adding the stack frame's size minus four to  $\$sp$  and storing the sum in register  $\$fp$ .

### Hardware Software Interface

The MIPS register use convention provides callee- and caller-saved registers because both types of registers are advantageous in different circumstances. Callee-saved registers are better used to hold long-lived values, such as variables from a user's program. These registers are only saved during a procedure call if the callee expects to use the register. On the other hand, caller-saved registers are better used to hold short-lived quantities that do not persist across a call, such as immediate values in an address calculation. During a call, the callee can also use these registers for short-lived temporaries.



Finally, the callee returns to the caller by executing the following steps:

1. If the callee is a function that returns a value, place the returned value in register `$v0`.
2. Restore all callee-saved registers that were saved upon procedure entry.
3. Pop the stack frame by subtracting the frame size from `$sp`.
4. Return by jumping to the address in register `$ra`.

**Elaboration:** A programming language that does not permit recursive procedures—procedures that call themselves either directly or indirectly through a chain of calls—need not allocate frames on a stack. In a nonrecursive language, each procedure's frame may be statically allocated since only one invocation of a procedure can be active at a time. Older versions of Fortran prohibited recursion because statically allocated frames produced faster code on some older machines. However, on load-store architectures like MIPS, stack frames may be just as fast because a frame pointer register points directly to the active stack frame, which permits a single load or store instruction to access values in the frame. In addition, recursion is a valuable programming technique.

## Procedure Call Example

As an example, consider the C routine

```
main ()
{
    printf ("The factorial of 10 is %d\n", fact (10));
}

int fact (int n)
{
    if (n < 1)
        return (1);
    else
        return (n * fact (n - 1));
}
```

which computes and prints 10! (the factorial of 10,  $10! = 10 \times 9 \times \dots \times 1$ ). `fact` is a recursive routine that computes  $n!$  by multiplying  $n$  times  $(n - 1)!$ . The assembly code for this routine illustrates how programs manipulate stack frames.

Upon entry, the routine `main` creates its stack frame and saves the two callee-saved registers it will modify: `$fp` and `$ra`. The frame is larger than required for these two registers because the calling convention requires the minimum size of a stack frame to be 24 bytes. This minimum frame can hold four

**argument registers (\$a0-\$a3) and the return address \$ra, padded to a doubleword boundary (24 bytes). Since main also needs to save \$fp, its stack frame must be two words larger (remember: the stack pointer is kept doubleword aligned).**

```

        .text
        .globl main
main:
    subu    $sp, $sp, 32    # Stack frame is 32 bytes long
    sw     $ra, 20($sp)    # Save return address
    sw     $fp, 16($sp)    # Save old frame pointer
    addu   $fp, $sp, 28    # Set up frame pointer

```

**The routine main then calls the factorial routine and passes it the single argument 10. After fact returns, main calls the library routine printf and passes it both a format string and the result returned from fact:**

```

    li     $a0, 10          # Put argument (10) in $a0
    jal   fact             # Call factorial function

    la    $a0, $LC         # Put format string in $a0
    move  $a1, $v0         # Move fact result to $a1
    jal   printf           # Call the print function

```

**Finally, after printing the factorial, main returns. But first, it must restore the registers it saved and pop its stack frame:**

```

    lw     $ra, 20($sp)    # Restore return address
    lw     $fp, 16($sp)    # Restore frame pointer
    addu   $sp, $sp, 32    # Pop stack frame
    jr    $ra             # Return to caller

.rdata
$LC:
.asciiz  "The factorial of 10 is %d\n\000"

```

**The factorial routine is similar in structure to main. First, it creates a stack frame and saves the callee-saved registers it will use. In addition to saving \$ra and \$fp, fact also saves its argument (\$a0), which it will use for the recursive call:**

```

        .text
fact:
    subu    $sp, $sp, 32    # Stack frame is 32 bytes long
    sw     $ra, 20($sp)    # Save return address
    sw     $fp, 16($sp)    # Save frame pointer
    addu   $fp, $sp, 28    # Set up frame pointer
    sw     $a0, 0($fp)     # Save argument (n)

```

The heart of the `fact` routine performs the computation from the C program. It tests if the argument is greater than 0. If not, the routine returns the value 1. If the argument is greater than 0, the routine recursively calls itself to compute `fact(n-1)` and multiplies that value times `n`:

```

        lw      $v0, 0($fp)      # Load n
        bgtz   $v0, $L2        # Branch if n > 0
        li     $v0, 1          # Return 1
        j      $L1             # Jump to code to return

$L2:
        lw      $v1, 0($fp)      # Load n
        subu   $v0, $v1, 1      # Compute n - 1
        move   $a0, $v0         # Move value to $a0
        jal    fact            # Call factorial function

        lw      $v1, 0($fp)      # Load n
        mul    $v0, $v0, $v1    # Compute fact(n-1) * n

```

Finally, the factorial routine restores the callee-saved registers and returns the value in register `$v0`:

```

$L1:
        lw      $ra, 20($sp)    # Restore $ra
        lw      $fp, 16($sp)    # Restore $fp
        addu   $sp, $sp, 32     # Pop stack
        j      $ra             # Return to caller

```

### Stack in Recursive Procedure

#### Example

Figure A.12 shows the stack at the call `fact(7)`. `main` runs first, so its frame is deepest on the stack. `main` calls `fact(10)`, whose stack frame is next on the stack. Each invocation recursively invokes `fact` to compute the next-lowest factorial. The stack frames parallel the LIFO order of these calls. What does the stack look like when the call to `fact(10)` returns?

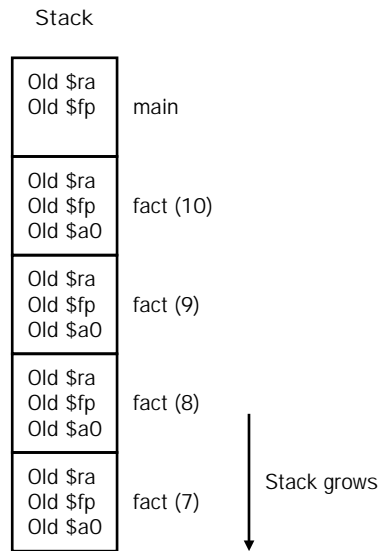
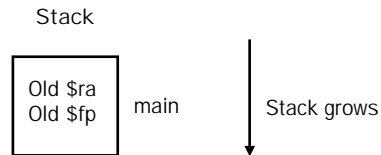

FIGURE A.12 Stack frames during the call of fact(7).

Answer



**Elaboration:** The difference between the MIPS compiler and the gcc compiler is that the MIPS compiler usually does not use a frame pointer, so this register is available as another callee-saved register, `$s8`. This change saves a couple of instructions in the procedure call and return sequence. However, it complicates code generation because a procedure must access its stack frame with `$sp`, whose value can change during a procedure's execution if values are pushed on the stack.

## Another Procedure Call Example

As another example, consider the following routine that computes the `tak` function, which is a widely used benchmark created by Ikuo Takeuchi. This function does not compute anything useful, but is a heavily recursive program that illustrates the MIPS calling convention.

```

int tak (int x, int y, int z)
{
    if (y < x)
        return 1+ tak (tak (x - 1, y, z),
            tak (y - 1, z, x),
            tak (z - 1, x, y));
    else
        return z;
}

int main ()
{
    tak(18, 12, 6);
}

```

The assembly code for this program is below. The `tak` function first saves its return address in its stack frame and its arguments in callee-saved registers, since the routine may make calls that need to use registers `$a0`–`$a2` and `$ra`. The function uses callee-saved registers since they hold values that persist over the lifetime of the function, which includes several calls that could potentially modify registers.

```

    .text
    .globl tak

tak:
    subu    $sp, $sp, 40
    sw     $ra, 32($sp)

    sw     $s0, 16($sp)    # x
    move   $s0, $a0
    sw     $s1, 20($sp)    # y
    move   $s1, $a1
    sw     $s2, 24($sp)    # z
    move   $s2, $a2
    sw     $s3, 28($sp)    # temporary

```

The routine then begins execution by testing if  $y < x$ . If not, it branches to label `L1`, which is below.

```

    bge    $s1, $s0, L1    # if (y < x)

```

If  $y < x$ , then it executes the body of the routine, which contains four recursive calls. The first call uses almost the same arguments as its parent:

```

    addu   $a0, $s0, -1
    move   $a1, $s1
    move   $a2, $s2
    jal    tak                # tak (x - 1, y, z)
    move   $s3, $v0

```

Note that the result from the first recursive call is saved in register \$s3, so that it can be used later.

The function now prepares arguments for the second recursive call.

```

addu    $a0, $s1, -1
move    $a1, $s2
move    $a2, $s0
jal     tak          # tak (y - 1, z, x)

```

In the instructions below, the result from this recursive call is saved in register \$s0. But, first we need to read, for the last time, the saved value of the first argument from this register.

```

addu    $a0, $s2, -1
move    $a1, $s0
move    $a2, $s1
move    $s0, $v0
jal     tak          # tak (z - 1, x, y)

```

After the three inner recursive calls, we are ready for the final recursive call. After the call, the function's result is in \$v0 and control jumps to the function's epilogue.

```

move    $a0, $s3
move    $a1, $s0
move    $a2, $v0
jal     tak          # tak (tak(...), tak(...), tak(...))
j       L2

```

This code at label L1 is the consequent of the *if-then-else* statement. It just moves the value of argument z into the return register and falls into the function epilogue.

```

L1:
move    $v0, $s2

```

The code below is the function epilogue, which restores the saved registers and returns the function's result to its caller.

```

L2:
lw      $ra, 32($sp)
lw      $s0, 16($sp)
lw      $s1, 20($sp)
lw      $s2, 24($sp)
lw      $s3, 28($sp)
addu    $sp, $sp, 40
j       $ra

```

The `main` routine calls the `tak` function with its initial arguments, then takes the computed result (7) and prints it using SPIM's system call for printing integers.

```

        .globl  main
main:
        subu   $sp, $sp, 24
        sw    $ra, 16($sp)

        li    $a0, 18
        li    $a1, 12
        li    $a2, 6
        jal   tak           # tak(18, 12, 6)
        move  $a0, $v0
        li    $v0, 1       # print_int syscall
        syscall

        lw    $ra, 16($sp)
        addu  $sp, $sp, 24
        j     $ra

```

## A.7

### Exceptions and Interrupts

Section 5.6 of Chapter 5 describes the MIPS exception facility, which responds both to exceptions caused by errors during an instruction's execution and to external interrupts caused by I/O devices. This section describes exception and interrupt handling in more detail. In MIPS processors, a part of the CPU called *coprocessor 0* records the information the software needs to handle exceptions and interrupts. The MIPS simulator SPIM does not implement all of coprocessor 0's registers, since many are not useful in a simulator or are part of the memory system, which SPIM does not implement. However, SPIM does provide the following coprocessor 0 registers:

Register name	Register number	Usage
BadVAddr	8	register containing the memory address at which memory reference occurred
Status	12	interrupt mask and enable bits
Cause	13	exception type and pending interrupt bits
EPC	14	register containing address of instruction that caused exception

These four registers are part of coprocessor 0's register set and are accessed by the `lwc0`, `mfc0`, `mtc0`, and `swc0` instructions. After an exception, register EPC

contains the address of the instruction that was executing when the exception occurred. If the instruction made a memory access that caused the exception, register `BadVAddr` contains the referenced memory location's address. The two other registers contain main fields and are described below.

Figure A.13 shows the Status register fields implemented by the MIPS simulator SPIM. The `interrupt mask` field contains a bit for each of the five hardware and three software possible interrupt levels. A bit that is 1 allows interrupts at that level. A bit that is 0 disables interrupts at that level. The low 6 bits of the Status register implement a three-deep stack for the `kernel /user` and `interrupt enable` bits. The `kernel /user` bit is 0 if a program was in the kernel when an exception occurred and 1 if it was running in user mode. If the `interrupt enable` bit is 1, interrupts are allowed. If it is 0, they are disabled. When an interrupt occurs, these 6 bits are shifted left by 2 bits, so the current bits become the previous bits and the previous bits become the old bits (the old bits are discarded). The current bits are both set to 0 so the interrupt handler runs in the kernel with interrupts disabled.

Figure A.14 shows the Cause register fields implemented by SPIM. The five `pending interrupt` bits correspond to the five interrupt levels. A bit becomes 1 when an interrupt at its level has occurred but has not been serviced. The Exception code register describes the cause of an exception with the following codes:

Number	Name	Description
0	INT	external interrupt
4	ADDRL	address error exception (load or instruction fetch)
5	ADDRS	address error exception (store)
6	IBUS	bus error on instruction fetch
7	DBUS	bus error on data load or store
8	SYSCALL	syscall exception
9	BKPT	breakpoint exception
10	RI	reserved instruction exception
12	OVF	arithmetic overflow exception

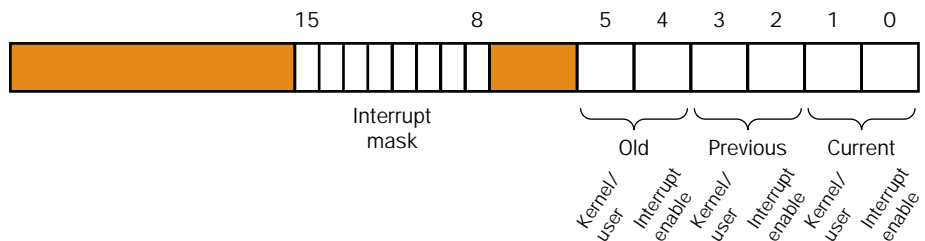

FIGURE A.13 The Status register.



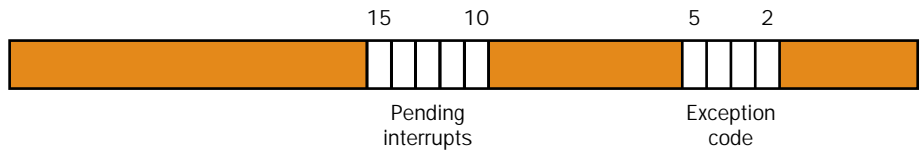

FIGURE A.14 The Cause register. In actual MIPS processors, this register contains additional fields that report: whether the instruction that caused the exception executed in a branch's delay slot, which coprocessor caused the exception, or that a software interrupt is pending.

Exceptions and interrupts cause a MIPS processor to jump to a piece of code, at address  $80000080_{\text{hex}}$  (in the kernel, not user address space), called an *interrupt handler*. This code examines the exception's cause and jumps to an appropriate point in the operating system. The operating system responds to an exception either by terminating the process that caused the exception or by performing some action. A process that causes an error, such as executing an unimplemented instruction, is killed by the operating system. On the other hand, exceptions such as page faults are requests from a process to the operating system to perform a service, such as bringing in a page from disk. The operating system processes these requests and resumes the process. The final type of exceptions are interrupts from external devices. These generally cause the operating system to move data to or from an I/O device and resume the interrupted process. The code in the example below is a simple interrupt handler, which invokes a routine to print a message at each exception (but not interrupts). This code is similar to the interrupt handler used by the SPIM simulator, except that it does not print an error message to report an exception.

#### Interrupt Handler

#### Example

The interrupt handler first saves registers `$a0` and `$a1`, which it later uses to pass arguments. The interrupt handler cannot store the old values from these registers on the stack, as would an ordinary routine, because the cause of the interrupt might have been a memory reference that used a bad value (such as 0) in the stack pointer. Instead the interrupt handler stores these registers in two memory locations (`save0` and `save1`). If the interrupt routine itself could be interrupted, two locations would not be enough since the second interrupt would overwrite values saved during the first interrupt. However, this simple interrupt handler finishes running before it enables interrupts, so the problem does not arise.

```

.ktext 0x80000080
sw $a0, save0 # Handler is not re-entrant and can't use
sw $a1, save1 # stack to save $a0, $a1
                # Don't need to save $k0/$k1

```

The interrupt handler then moves the Cause and EPC registers into CPU registers. The Cause and EPC registers are not part of the CPU register set. Instead, they are registers in coprocessor 0, which is the part of the CPU that handles interrupts. The instruction `mfc0 $k0, $13` moves coprocessor 0's register 13 (the Cause register) into CPU register `$k0`. Note that the interrupt handler need not save registers `$k0` and `$k1` because user programs are not supposed to use these registers. The interrupt handler uses the value from the Cause register to test if the exception was caused by an interrupt (see the preceding table). If so, the exception is ignored. If the exception was not an interrupt, the handler calls `print_excp` to print a warning message.

```

mfc0    $k0, $13      # Move Cause into $k0
mfc0    $k1, $14      # Move EPC into $k1

sgt     $v0, $k0, 0x44 # Ignore interrupts
bgtz   $v0, done

mov     $a0, $k0      # Move Cause into $a0
mov     $a1, $k1      # Move EPC into $a1
jal     print_excp    # Print exception error message

```

Before returning, the interrupt handler restores registers `$a0` and `$a1`. It then executes the `rfe` (return from exception) instruction, which restores the previous interrupt mask and kernel/user bits in the Status register. This switches the processor state back to what it was before the exception and prepares to resume program execution. The interrupt handler then returns to the program by jumping to the instruction following the one that caused the exception.

```

done:
    lw     $a0, save0
    lw     $a1, save1
    addiu $k1, $k1, 4 # Do not reexecute
                    # faulting instruction
    rfe
    jr    $k1

.kdata
save0: .word 0
save1: .word 0

```

**Elaboration:** On real MIPS processors, the return from an interrupt handler is more complex. The `rfe` instruction must execute in the delay slot of the `jr` instruction (see elaboration on page 444 of Chapter 6) that returns to the user program so that no interrupt-handler instruction executes with the user program's interrupt mask and kernel/user bits. In addition, the interrupt handler cannot always jump to the instruction following EPC. For example, if the instruction that caused the exception was in a branch instruction's delay slot (see Chapter 6), the next instruction may not be the following instruction in memory.

## A.8

### Input and Output

SPIM simulates one I/O device: a memory-mapped terminal. When a program is running, SPIM connects its own terminal (or a separate console window in the X-window version `xsxim`) to the processor. A MIPS program running on SPIM can read the characters that you type. In addition, if the MIPS program writes characters to the terminal, they appear on SPIM's terminal or console window. One exception to this rule is control-C: this character is not passed to the program, but instead causes SPIM to stop and return to command mode. When the program stops running (for example, because you typed control-C or because the program hit a breakpoint), the terminal is reconnected to `spim` so you can type SPIM commands. To use memory-mapped I/O (see below), `spim` or `xsxim` must be started with the `-mapped_i o` flag.

The terminal device consists of two independent units: a *receiver* and a *transmitter*. The receiver reads characters from the keyboard. The transmitter writes characters to the display. The two units are completely independent. This means, for example, that characters typed at the keyboard are not automatically echoed on the display. Instead, a program must explicitly echo a character by reading it from the receiver and writing it to the transmitter.

A program controls the terminal with four memory-mapped device registers, as shown in Figure A.15. "Memory-mapped" means that each register appears as a special memory location. The *Receiver Control register* is at location `ffff0000hex`. Only two of its bits are actually used. Bit 0 is called "ready": if it is 1, it means that a character has arrived from the keyboard but has not yet been read from the Receiver Data register. The ready bit is read-only: writes to it are ignored. The ready bit changes from 0 to 1 when a character is typed at the keyboard, and it changes from 1 to 0 when the character is read from the Receiver Data register.

Bit 1 of the Receiver Control register is the keyboard "interrupt enable." This bit may be both read and written by a program. The interrupt enable is initially 0. If it is set to 1 by a program, the terminal requests an interrupt at level 0 whenever the ready bit is 1. However, for the interrupt to affect the processor,

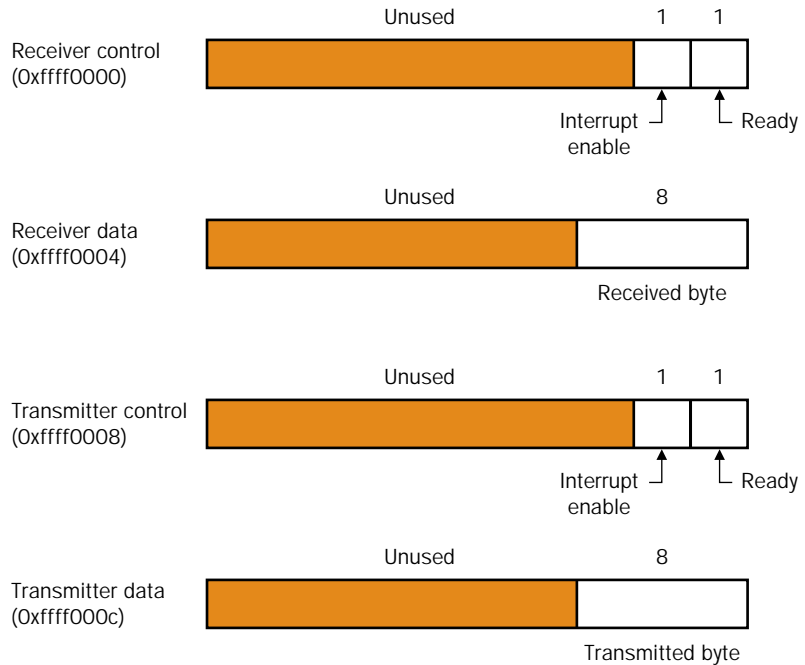

FIGURE A.15 The terminal is controlled by four device registers, each of which appears as a memory location at the given address. Only a few bits of these registers are actually used. The others always read as 0s and are ignored on writes.

interrupts must also be enabled in the Status register (see section A.7). All other bits of the Receiver Control register are unused.

The second terminal device register is the *Receiver Data register* (at address  $\text{ffff0004}_{\text{hex}}$ ). The low-order 8 bits of this register contain the last character typed at the keyboard. All other bits contain 0s. This register is read-only and changes only when a new character is typed at the keyboard. Reading the Receiver Data register resets the ready bit in the Receiver Control register to 0.

The third terminal device register is the *Transmitter Control register* (at address  $\text{ffff0008}_{\text{hex}}$ ). Only the low-order 2 bits of this register are used. They behave much like the corresponding bits of the Receiver Control register. Bit 0 is called “ready” and is read-only. If this bit is 1, the transmitter is ready to accept a new character for output. If it is 0, the transmitter is still busy writing the previous character. Bit 1 is “interrupt enable” and is readable and writable. If this bit is set to 1, then the terminal requests an interrupt on level 1 whenever the ready bit is 1.

The final device register is the *Transmitter Data register* (at address  $\text{ffff000c}_{\text{hex}}$ ). When a value is written into this location, its low-order 8 bits (i.e.,

an ASCII character as in Figure 3.15 in Chapter 3) are sent to the console. When the Transmitter Data register is written, the ready bit in the Transmitter Control register is reset to 0. This bit stays 0 until enough time has elapsed to transmit the character to the terminal; then the ready bit becomes 1 again. The Transmitter Data register should only be written when the ready bit of the Transmitter Control register is 1. If the transmitter is not ready, writes to the Transmitter Data register are ignored (the write appears to succeed but the character is not output).

Real computers require time to send characters over the serial lines that connect terminals to computers. These time lags are simulated by SPIM. For example, after the transmitter starts to write a character, the transmitter's ready bit becomes 0 for a while. SPIM measures time in instructions executed, not in real clock time. This means that the transmitter does not become ready again until the processor executes a certain number of instructions. If you stop the machine and look at the ready bit, it will not change. However, if you let the machine run, the bit eventually changes back to 1.

## A.9

### SPIM

SPIM is a software simulator that runs programs written for MIPS R2000/R3000 processors. SPIM's name is just MIPS spelled backwards. SPIM can read and immediately execute assembly language files or (on some systems) MIPS executable files. SPIM is a self-contained system for running MIPS programs. It contains a debugger and provides a few operating system-like services. SPIM is much slower than a real computer (100 or more times). However, its low cost and wide availability cannot be matched by real hardware!

An obvious question is, Why use a simulator when many people have workstations that contain MIPS chips that are significantly faster than SPIM? One reason is that these workstations are not universally available. Another reason is rapid progress toward new and faster computers may render these machines obsolete (see Chapter 1). The current trend is to make computers faster by executing several instructions concurrently. This trend makes architectures more difficult to understand and program. The MIPS architecture may be the epitome of a simple, clean RISC machine.

In addition, simulators can provide a better environment for programming than an actual machine because they can detect more errors and provide more features than an actual computer. For example, SPIM has an X-window interface that works better than most debuggers on the actual machines.

Finally, simulators are a useful tool in studying computers and the programs that run on them. Because they are implemented in software, not silicon, simulators can be easily modified to add new instructions, build new systems such as multiprocessors, or simply to collect data.

## Simulation of a Virtual Machine

The MIPS architecture, like that of many RISC computers, is difficult to program directly because of delayed branches, delayed loads, and restricted address modes. This difficulty is tolerable since these computers were designed to be programmed in high-level languages and present an interface appropriate for compilers rather than assembly language programmers. A good part of the programming complexity results from delayed instructions. A *delayed branch* requires two cycles to execute (see elaborations on pages 444 and 502 of Chapter 6). In the second cycle, the instruction immediately following the branch executes. This instruction can perform useful work that normally would have been done before the branch. It can also be a *nop* (no operation). Similarly, *delayed loads* require two cycles so the instruction immediately following a load cannot use the value loaded from memory (see section 6.2 of Chapter 6).

MIPS wisely chose to hide this complexity by having its assembler implement a *virtual machine*. This virtual computer appears to have nondelayed branches and loads and a richer instruction set than the actual hardware. The assembler *reorganizes* (rearranges) instructions to fill the delay slots. The virtual computer also provides *pseudoinstructions*, which appear as real instructions in assembly language programs. The hardware, however, knows nothing about pseudoinstructions, so the assembler must translate them into equivalent sequences of actual, machine instructions. For example, the MIPS hardware only provides instructions to branch when a register is equal to or not equal to 0. Other conditional branches, such as when one register is greater than another, are synthesized by comparing the two registers and branching when the result of the comparison is true (nonzero).

By default, SPIM simulates the richer virtual machine. However, it can also simulate the bare hardware. Below, we describe the virtual machine and only mention in passing features that do not belong to the actual hardware. In doing so, we follow the convention of MIPS assembly language programmers (and compilers), who routinely use the extended machine. (For a description of the real machines, see Gerry Kane and Joe Heinrich, *MIPS RISC Architecture*, Prentice Hall, Englewood Cliff, NJ, 1992.)

## Getting Started with SPIM

The rest of this appendix contains a complete and rather detailed description of SPIM. Many details should never concern you; however, the sheer volume of information can obscure the fact that SPIM is a simple, easy-to-use program. This section contains a quick tutorial on SPIM that should enable you to load, debug, and run simple MIPS programs.



SPIM comes in multiple versions. One version, called `spim`, is a command-line-driven program and requires only an alphanumeric terminal to display it. It operates like most programs of this type: you type a line of text, hit the return key, and `spim` executes your command.

A fancier version, called `xspim`, runs in the X-windows environment of the Unix system and therefore requires a bit-mapped display to run it. `xspim`, however, is a much easier program to learn and use because its commands are always visible on the screen and because it continually displays the machine's registers. Another version, `PCspim`, is compatible with Windows 3.1, Windows 95, and Windows NT. The Unix, Windows, and DOS versions of SPIM are available through [www.mkp.com/cod2e.htm](http://www.mkp.com/cod2e.htm).

Since many people use and prefer `xspim`, this section only discusses that program. If you plan to use any version of `spim`, do not skip this section. Read it first and then look at the "SPIM Command-Line Options" section (starting on page A-44) to see how to accomplish the same thing with `spim` commands. Check [www.mkp.com/cod2e.htm](http://www.mkp.com/cod2e.htm) for more information on using `PCspim`.

To start `xspim`, type `xspim` in response to your system's prompt (%):

```
% xspim
```

On your system, `xspim` may be kept in an unusual place, and you may need to execute a command first to add that place to your search path. Your instructor should tell you how to do this.

When `xspim` starts up, it pops up a large window on your screen (see Figure A.16). The window is divided into five panes:

- The top pane is called the *register display*. It shows the values of all registers in the MIPS CPU and FPU. This display is updated whenever your program stops running.
- The pane below contains the *control buttons* to operate `xspim`. These buttons are discussed below, so we can skip the details for now.
- The next pane, called the *text segments*, displays instructions both from your program and the system code that is loaded automatically when `xspim` starts running. Each instruction is displayed on a line that looks like

```
[0x00400000] 0x8fa40000 lw $4, 0($29) ; 89: lw $a0, 0($sp)
```

The first number on the line, in square brackets, is the hexadecimal memory address of the instruction. The second number is the instruction's numerical encoding, again displayed as a hexadecimal number. The third item is the instruction's mnemonic description. Everything following the semicolon is the actual line from your assembly file that produced the instruction. The number 89 is the line number in that file. Sometimes nothing is on the line after the semicolon. This means that the instruction was produced by SPIM as part of translating a pseudo-instruction.

xspim	
	PC = 00000000 EPC = 00000000 Cause = 00000000 BadVaddr = 00000000 Status = 00000000 HI = 00000000 LO = 00000000
	<b>General registers</b>
Register display	R0 (r0) = 00000000 R8 (t0) = 00000000 R16 (s0) = 00000000 R24 (t8) = 00000000 R1 (a1) = 00000000 R9 (t1) = 00000000 R17 (s1) = 00000000 R25 (s9) = 00000000 R2 (v0) = 00000000 R10 (t2) = 00000000 R18 (s2) = 00000000 R26 (k0) = 00000000 R3 (v1) = 00000000 R11 (t3) = 00000000 R19 (s3) = 00000000 R27 (k1) = 00000000 R4 (a0) = 00000000 R12 (t4) = 00000000 R20 (s4) = 00000000 R28 (gp) = 00000000 R5 (a1) = 00000000 R13 (t5) = 00000000 R21 (s5) = 00000000 R29 (sp) = 00000000 R6 (a2) = 00000000 R14 (t6) = 00000000 R22 (s6) = 00000000 R30 (s8) = 00000000 R7 (a3) = 00000000 R15 (t7) = 00000000 R23 (s7) = 00000000 R31 (ra) = 00000000
	<b>Double floating-point registers</b>
	FP0 = 0.000000 FP8 = 0.000000 FP16 = 0.000000 FP24 = 0.000000 FP2 = 0.000000 FP10 = 0.000000 FP18 = 0.000000 FP26 = 0.000000 FP4 = 0.000000 FP12 = 0.000000 FP20 = 0.000000 FP28 = 0.000000 FP6 = 0.000000 FP14 = 0.000000 FP22 = 0.000000 FP30 = 0.000000
	<b>Single floating-point registers</b>
Control buttons	<div style="display: flex; flex-wrap: wrap; justify-content: space-around;"> <div style="border: 1px solid black; padding: 2px 10px; margin: 2px;">quit</div> <div style="border: 1px solid black; padding: 2px 10px; margin: 2px;">load</div> <div style="border: 1px solid black; padding: 2px 10px; margin: 2px;">run</div> <div style="border: 1px solid black; padding: 2px 10px; margin: 2px;">step</div> <div style="border: 1px solid black; padding: 2px 10px; margin: 2px;">clear</div> <div style="border: 1px solid black; padding: 2px 10px; margin: 2px;">set value</div> <div style="border: 1px solid black; padding: 2px 10px; margin: 2px;">print</div> <div style="border: 1px solid black; padding: 2px 10px; margin: 2px;">breakpt</div> <div style="border: 1px solid black; padding: 2px 10px; margin: 2px;">help</div> <div style="border: 1px solid black; padding: 2px 10px; margin: 2px;">terminal</div> <div style="border: 1px solid black; padding: 2px 10px; margin: 2px;">mode</div> </div>
	<b>Text segments</b>
Text segments	<pre> [0x00400000] 0x8fa40000 lw \$4, 0(\$29) ; 89: lw \$a0, 0(\$sp) [0x00400004] 0x27a50004 addiu \$5, \$29, 4 ; 90: addiu \$a1, \$sp, 4 [0x00400008] 0x24a60004 addiu \$6, \$5, 4 ; 91: addiu \$a2, \$a1, 4 [0x0040000c] 0x00041080 sll \$2, \$4, 2 ; 92: sll \$v0, \$a0, 2 [0x00400010] 0x00c23021 addu \$6, \$6, \$2 ; 93: addu \$a2, \$a2, \$v0 [0x00400014] 0x0c000000 jal 0x00000000 [mai n] ; 94: jal mai n [0x00400018] 0x3402000a ori \$2, \$0, 10 ; 95: li \$v0 10 [0x0040001c] 0x0000000c syscall ; 96: syscall           </pre>
	<b>Data segments</b>
Data and stack segments	<pre> [0x10000000] ... [0x10010000] 0x00000000 [0x10010004] 0x74706563 0x206e6f69 0x636f2000 [0x10010010] 0x72727563 0x61206465 0x6920646e 0x726f6e67 [0x10010020] 0x000a6465 0x495b2020 0x7265746e 0x74707572 [0x10010030] 0x0000205d 0x20200000 0x616e555b 0x6e67696c [0x10010040] 0x61206465 0x65726464 0x69207373 0x6e69206e [0x10010050] 0x642f7473 0x20617461 0x63746566 0x00205d68 [0x10010060] 0x555b2020 0x696c616e 0x64656e67 0x64646120 [0x10010070] 0x73736572 0x206e6920 0x726f7473 0x00205d65           </pre>
SPIM messages	SPIM Version 5.9 of January 17, 1997 Copyright (c) 1990-1997 by James R. Larus (larus@cs.wisc.edu) All Rights Reserved. See the file README for a full copyright notice.

FIGURE A.16 SPIM's X-window interface: xspim.



- The next pane, called the *data and stack segments*, displays the data loaded into your program's memory and the data on the program's stack.
- The bottom pane is the *SPIM messages* that `xspi m` uses to write messages. This is where error messages appear.

Let's see how to load and run a program. The first thing to do is to click on the `load` button (the second one in the first row of buttons) with the left mouse key. Your click tells `xspi m` to pop up a small prompt window that contains a box and two or three buttons. Move your mouse so the cursor is over the box, and type the name of your file of assembly code. Then click on the button labeled `assembly file` within that prompt window. If you change your mind, click on the button labeled `abort command`, and `xspi m` gets rid of the prompt window. When you click on `assembly file`, `xspi m` gets rid of the prompt window, then loads your program and redraws the screen to display its instructions and data. Now move the mouse to put the cursor over the scrollbar to the left of the text segments, and click the left mouse button on the white part of this scrollbar. A click scrolls the text pane down so you can find all the instructions in your program.

To run your program, click on the `run` button in `xspi m`'s control button pane. It pops up a prompt window with two boxes and two buttons. Most of the time, these boxes contain the correct values to run your program, so you can ignore them and just click on `ok`. This button tells `xspi m` to run your program. Notice that when your program is running, `xspi m` blanks out the register display pane because the registers are continually changing. You can always tell whether `xspi m` is running by looking at this pane. If you want to stop your program, make sure the mouse cursor is somewhere over `xspi m`'s window and type control-C. This causes `xspi m` to pop up a prompt window with two buttons. Before doing anything with this prompt window, you can look at registers and memory to find out what your program was doing. When you understand what happened, you can either continue the program by clicking on `continue` or stop your program by clicking on `abort command`.

If your program reads or writes from the terminal, `xspi m` pops up another window called the *console*. All characters that your program writes appear on the console, and everything that you type as input to your program should be typed in this window.

Suppose your program does not do what you expect. What can you do? SPIM has two features that help debug your program. The first, and perhaps the most useful, is single-stepping, which allows you to run your program an instruction at a time. Click on the button labeled `step` and another prompt window pops up. This prompt window contains two boxes and three buttons. The first box asks for the number of instructions to step every time you click the mouse. Most of the time, the default value of 1 is a good choice. The other box asks for arguments to pass to the program when it starts running. Again,

most of the time you can ignore this box because it contains an appropriate value. The button labeled `step` runs your program for the number of instructions in the top box. If that number is 1, `xspi m` executes the next instruction in your program, updates the display, and returns control to you. The button labeled `continue` stops single-stepping and continues running your program. Finally, `abort` command stops single-stepping and leaves your program stopped.

What do you do if your program runs for a long time before the bug arises? You could single-step until you get to the bug, but that can take a long time, and it is easy to get so bored and inattentive that you step past the problem. A better alternative is to use a *breakpoint*, which tells `xspi m` to stop your program immediately before it executes a particular instruction. Click on the button in the second row of buttons marked `breakpoints`. The `xspi m` program pops up a prompt window with one box and many buttons. Type in this box the address of the instruction at which you want to stop. Or, if the instruction has a global label, you can just type the name of the label. Labeled breakpoints are a particularly convenient way to stop at the first instruction of a procedure. To actually set the breakpoint, click on `add`. You can then run your program.

When SPIM is about to execute the breakpointed instruction, `xspi m` pops up a prompt with the instruction's address and two buttons. The `continue` button continues running your program and `abort` command stops your program. If you want to delete a breakpoint, type in its address and click on `delete`. Finally, `list` tells `xspi m` to print (in the bottom pane) a list of all breakpoints that are set.

Single-stepping and setting breakpoints will probably help you find a bug in your program quickly. How do you fix it? Go back to the editor that you used to create your program and change it. To run the program again, you need a fresh copy of SPIM, which you get in two ways. Either you can exit from `xspi m` by clicking on the `quit` button, or you can clear `xspi m` and reload your program. If you reload your program, you *must* clear the memory, so remnants of your previous program do not interfere with your new program. To do this, click on the button labeled `clear`. Hold the left mouse key down and a two-item menu will pop up. Move the mouse so the cursor is over the item labeled `memory & registers` and release the key. This causes `xspi m` to clear its memory and registers and return the processor to the state it was in when `xspi m` first started. You can now load and run your new program.

The other buttons in `xspi m` perform functions that are occasionally useful. When you are more comfortable with `xspi m`, you should look at the description below to see what they do and how they can save you time and effort.

## SPIM Command-Line Options

Both Unix versions of SPIM—`spi m`, the terminal version, and `xspi m`, the X version—accept the following command-line options:

- bare            Simulate a bare MIPS machine without pseudoinstructions or the additional addressing modes provided by the assembler. Implies `-quiet`.
- asm            Simulate the virtual MIPS machine provided by the assembler. This is the default.
- pseudo        Allow the input assembly code to contain pseudoinstructions. This is the default.
- nopseudo     Do not allow pseudoinstructions in the input assembly code.
- notrap        Do not load the standard exception handler and start-up code. This exception handler handles exceptions. When an exception occurs, SPIM jumps to location `80000080hex`, which must contain code to service the exception. In addition, this file contains start-up code that invokes the routine `main`. Without the start-up routine, SPIM begins execution at the instruction labeled `__start`.
- trap          Load the standard exception handler and start-up code. This is the default.
- noquiet       Print a message when an exception occurs. This is the default.
- quiet         Do not print a message at exceptions.
- nomapped\_i o Disable the memory-mapped I/O facility (see section A.8). This is the default.
- mapped\_i o    Enable the memory-mapped I/O facility (see section A.8). Programs that use SPIM `syscall s` (see section on "System Calls," page A-48) to read from the terminal *cannot* also use memory-mapped I/O.
- file          Load and execute the assembly code in the file.
- execute       Load and execute the code in the MIPS executable file *a.out*. This command is only available when SPIM runs on a system containing a MIPS processor.

- `-s <seg> si ze` Sets the initial size of memory segment *seg* to be *size* bytes. The memory segments are named: `text`, `data`, `stack`, `ktext`, and `kdata`. The `text` segment contains instructions from a program. The `data` segment holds the program's data. The `stack` segment holds its runtime stack. In addition to running a program, SPIM also executes system code that handles interrupts and exceptions. This code resides in a separate part of the address space called the *kernel*. The `ktext` segment holds this code's instructions, and `kdata` holds its data. There is no `kstack` segment since the system code uses the same stack as the program. For example, the pair of arguments `-sdata 2000000` starts the user data segment at 2,000,000 bytes.
- `-l <seg> si ze` Sets the limit on how large memory segment *seg* can grow to be *size* bytes. The memory segments that can grow are `data`, `stack`, and `kdata`.

## Terminal Interface (spim)

The simpler Unix version of SPIM is called `spim`. It does not require a bit-mapped display and can be run from any terminal. Although `spim` may be more difficult to learn, it operates just like `xspim` and provides the same functionality.

The `spim` terminal interface provides the following commands:

- `exit` Exit the simulator.
- `read "file"` Read *file* of assembly language into SPIM. If the file has already been read into SPIM, the system must be cleared (see `reinitialize`, below) or global labels will be multiply defined.
- `load "file"` Synonym for `read`.
- `execute "a.out"` Read the MIPS executable file *a.out* into SPIM. This command is only available when SPIM runs on a system containing a MIPS processor.
- `run <addr>` Start running a program. If the optional address *addr* is provided, the program starts at that address. Otherwise, the program starts at the global label `__start`, which is usually the default start-up code that calls the routine at the global label `main`.

<code>step &lt;N&gt;</code>	Step the program for <i>N</i> (default: 1) instructions. Print instructions as they execute.
<code>continue</code>	Continue program execution without stepping.
<code>print \$N</code>	Print register <i>N</i> .
<code>print \$fN</code>	Print floating point register <i>N</i> .
<code>print addr</code>	Print the contents of memory at address <i>addr</i> .
<code>print_sym</code>	Print the names and addresses of the global labels known to SPIM. Labels are local by default and become global only when declared in a <code>.global</code> assembler directive (see "Assembler Syntax" section on page A-51).
<code>reinitialize</code>	Clear the memory and registers.
<code>breakpoint addr</code>	Set a breakpoint at address <i>addr</i> . <i>addr</i> can be either a memory address or symbolic label.
<code>delete addr</code>	Delete all breakpoints at address <i>addr</i> .
<code>list</code>	List all breakpoints.
<code>.</code>	Rest of line is an assembly instruction that is stored in memory.
<code>&lt;nl &gt;</code>	A newline reexecutes previous command.
<code>?</code>	Print a help message.

Most commands can be abbreviated to their unique prefix (e.g., `ex`, `re`, `l`, `ru`, `s`, `p`). More dangerous commands, such as `reinitialize`, require a longer prefix.

## X-Window Interface (`xspim`)

The tutorial, "Getting Started with SPIM" (page A-39), explains the most common `xspim` commands. However, `xspim` has other commands that are occasionally useful. This section provides a complete list of the commands.

The X version of SPIM, `xspim`, looks different but operates in the same manner as `spim`. The X-window has five panes (see Figure A.16). The top pane displays the registers. These values are continually updated, except while a program is running.

The next pane contains buttons that control the simulator:

<code>quit</code>	Exit from the simulator.
<code>load</code>	Read a source or executable file into SPIM.

---

run	Start the program running.
step	Single-step a program.
clear	Reinitialize registers or memory.
set value	Set the value in a register or memory location.
print	Print the value in a register or memory location.
breakpoint	Set or delete a breakpoint or list all breakpoints.
help	Print a help message.
terminal	Raise or hide the console window.
mode	Set SPIM operating modes.

The next two panes display the memory. The top one shows instructions from the user and kernel text segments. (These instructions are real—not pseudo—MIPS instructions. SPIM translates assembler pseudoinstructions into one to three MIPS instructions. Each source instruction appears as a comment on the first instruction into which it is translated.) The first few instructions in the text segment are the default start-up code (`__start`) that loads `argc` and `argv` into registers and invokes the `main` routine. The lower of these two panes displays the data and stack segments. Both panes are updated as a program executes.

The bottom pane is used to display SPIM messages. It does not display output from a program. When a program reads or writes, its I/O appears in a separate window, called the *console*, which pops up when needed.

## Surprising Features

Although SPIM faithfully simulates the MIPS computer, SPIM is a simulator and certain things are not identical to an actual computer. The most obvious differences are that instruction timing and the memory systems are not identical. SPIM does not simulate caches or memory latency, nor does it accurately reflect floating-point operation or multiply and divide instruction delays.

Another surprise (which occurs on the real machine as well) is that a pseudoinstruction expands to several machine instructions. When you single-step or examine memory, the instructions that you see are different from the source program. The correspondence between the two sets of instructions is fairly simple since SPIM does not reorganize instructions to fill delay slots.

## Byte Order

Processors can number bytes within a word so the byte with the lowest number is either the leftmost or rightmost one. The convention used by a machine

is called its *byte order*. MIPS processors can operate with either *big-endian* or *little-endian* byte order. For example, in a big-endian machine, the directive `.byte 0, 1, 2, 3` would result in a memory word containing

Byte #			
0	1	2	3

while in a little-endian machine, the word would contain

Byte #			
3	2	1	0

SPIM operates with both byte orders. SPIM's byte order is the same as the byte order of the underlying machine that runs the simulator. For example, on a DECstation 3100 or Intel 80x86, SPIM is little-endian, while on a Macintosh or Sun SPARC, SPIM is big-endian.

## System Calls

SPIM provides a small set of operating-system-like services through the system call (`syscall`) instruction. To request a service, a program loads the system call code (see Figure A.17) into register `$v0` and arguments into registers `$a0-$a3` (or `$f12` for floating-point values). System calls that return values put their results in register `$v0` (or `$f0` for floating-point results). For example, the following code prints "the answer = 5":

```
.data
str:
.asciiz "the answer = "
.text
li      $v0, 4      # system call code for print_str
la      $a0, str    # address of string to print
syscall                               # print the string

li      $v0, 1      # system call code for print_int
li      $a0, 5      # integer to print
syscall                               # print it
```

The `print_int` system call is passed an integer and prints it on the console. `print_float` prints a single floating-point number; `print_double` prints a double precision number; and `print_string` is passed a pointer to a null-terminated string, which it writes to the console.

Service	System call code	Arguments	Result
print_int	1	\$a0 = integer	
print_float	2	\$f12 = float	
print_double	3	\$f12 = double	
print_string	4	\$a0 = string	
read_int	5		integer (in \$v0)
read_float	6		float (in \$f0)
read_double	7		double (in \$f0)
read_string	8	\$a0 = buffer, \$a1 = length	
sbrk	9	\$a0 = amount	address (in \$v0)
exit	10		

FIGURE A.17 System services.

The system calls `read_int`, `read_float`, and `read_double` read an entire line of input up to and including the newline. Characters following the number are ignored. `read_string` has the same semantics as the Unix library routine `fgets`. It reads up to  $n - 1$  characters into a buffer and terminates the string with a null byte. If fewer than  $n - 1$  characters are on the current line, `read_string` reads up to and including the newline and again null-terminates the string. **Warning:** Programs that use these syscalls to read from the terminal should not use memory-mapped I/O (see section A.8).

Finally, `sbrk` returns a pointer to a block of memory containing  $n$  additional bytes, and `exit` stops a program from running.

## A.10

### MIPS R2000 Assembly Language

A MIPS processor consists of an integer processing unit (the CPU) and a collection of coprocessors that perform ancillary tasks or operate on other types of data such as floating-point numbers (see Figure A.18). SPIM simulates two coprocessors. Coprocessor 0 handles exceptions, interrupts, and the virtual memory system. SPIM simulates most of the first two and entirely omits details of the memory system. Coprocessor 1 is the floating-point unit. SPIM simulates most aspects of this unit.

#### Addressing Modes

MIPS is a load-store architecture, which means that only load and store instructions access memory. Computation instructions operate only on values in registers. The bare machine provides only one memory-addressing mode: `c(rx)`, which uses the sum of the immediate `c` and register `rx` as the address. The virtual machine provides the following addressing modes for load and store instructions:



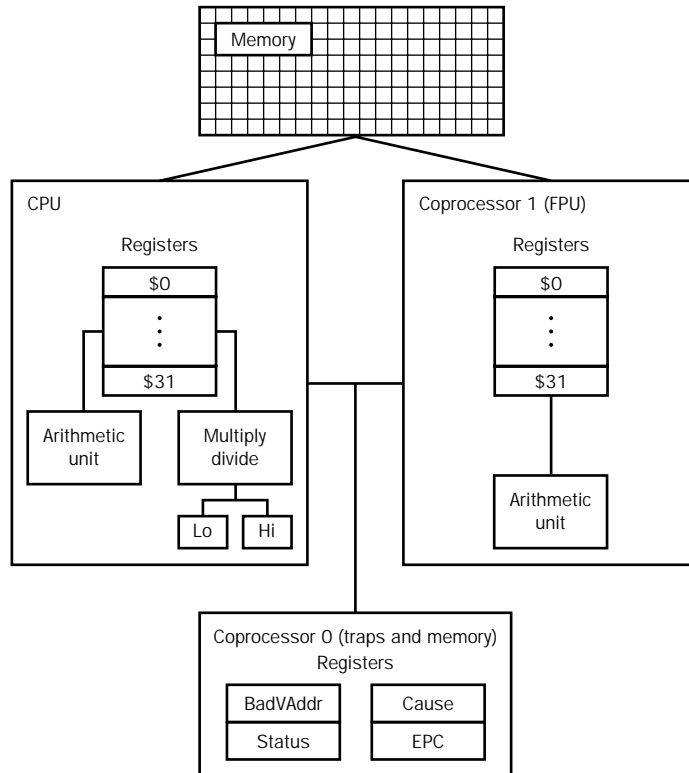

FIGURE A.18 MIPS R2000 CPU and FPU.

Format	Address computation
(register)	contents of register
imm	immediate
imm (register)	immediate + contents of register
label	address of label
label ± imm	address of label + or - immediate
label ± imm (register)	address of label + or - (immediate + contents of register)

Most load and store instructions operate only on aligned data. A quantity is *aligned* if its memory address is a multiple of its size in bytes. Therefore, a half-word object must be stored at even addresses and a full word object must be stored at addresses that are a multiple of four. However, MIPS provides some instructions to manipulate unaligned data (`lwl`, `lwr`, `swl`, and `swr`).

**Elaboration:** The MIPS assembler (and SPIM) synthesizes the more complex addressing modes by producing one or more instructions before the load or store to compute a complex address. For example, suppose that the label `table` referred to memory location `0x10000004` and a program contained the instruction

```
ld $a0, table + 4($a1)
```

The assembler would translate this instruction into the instructions

```
lui $at, 4096
addu $at, $at, $a1
lw $a0, 8($at)
```

The first instruction loads the upper bits of the label's address into register `$at`, which the register that the assembler reserves for its own use. The second instruction adds the contents of register `$a1` to the label's partial address. Finally, the load instruction uses the hardware address mode to add the sum of the lower bits of the label's address and the offset from the original instruction to the value in register `$at`.

## Assembler Syntax

Comments in assembler files begin with a sharp sign (`#`). Everything from the sharp sign to the end of the line is ignored.

Identifiers are a sequence of alphanumeric characters, underbars (`_`), and dots (`.`) that do not begin with a number. Instruction opcodes are reserved words that *cannot* be used as identifiers. Labels are declared by putting them at the beginning of a line followed by a colon, for example:

```
.data
item: .word 1
      .text
      .globl main # Must be global
main: lw    $t0, item
```

Numbers are base 10 by default. If they are preceded by `0x`, they are interpreted as hexadecimal. Hence, `256` and `0x100` denote the same value.

Strings are enclosed in doublequotes (`"`). Special characters in strings follow the C convention:

- `newline` `\n`
- `tab` `\t`
- `quote` `\"`

SPIM supports a subset of the MIPS assembler directives:

```
.align n      Align the next datum on a 2n byte boundary. For example,
               .align 2 aligns the next value on a word boundary.
               .align 0 turns off automatic alignment of .half, .word,
               .float, and .double directives until the next .data or
               .kdata directive.

.asci str     Store the string str in memory, but do not null-terminate it.
```

- `.asciiz str` Store the string *str* in memory and null-terminate it.
- `.byte b1, ..., bn` Store the *n* values in successive bytes of memory.
- `.data <addr>` Subsequent items are stored in the data segment. If the optional argument *addr* is present, subsequent items are stored starting at address *addr*.
- `.double d1, ..., dn` Store the *n* floating-point double precision numbers in successive memory locations.
- `.extern sym size` Declare that the datum stored at *sym* is *size* bytes large and is a global label. This directive enables the assembler to store the datum in a portion of the data segment that is efficiently accessed via register `$gp`.
- `.float f1, ..., fn` Store the *n* floating-point single precision numbers in successive memory locations.
- `.global sym` Declare that label *sym* is global and can be referenced from other files.
- `.half h1, ..., hn` Store the *n* 16-bit quantities in successive memory halfwords.
- `.kdata <addr>` Subsequent data items are stored in the kernel data segment. If the optional argument *addr* is present, subsequent items are stored starting at address *addr*.
- `.ktext <addr>` Subsequent items are put in the kernel text segment. In SPIM, these items may only be instructions or words (see the `.word` directive below). If the optional argument *addr* is present, subsequent items are stored starting at address *addr*.
- `.set noat` and `.set at` The first directive prevents SPIM from complaining about subsequent instructions that use register `$at`. The second directive reenables the warning. Since pseudoinstructions expand into code that uses register `$at`, programmers must be very careful about leaving values in this register.
- `.space n` Allocate *n* bytes of space in the current segment (which must be the data segment in SPIM).
- `.text <addr>` Subsequent items are put in the user text segment. In SPIM, these items may only be instructions or words (see the `.word` directive below). If the optional argument *addr* is present, subsequent items are stored starting at address *addr*.

`.word w1, ..., wn` Store the  $n$  32-bit quantities in successive memory words.

SPIM does not distinguish various parts of the data segment (`.data`, `.rdata`, and `.sdata`).

## Encoding MIPS Instructions

Figure A.19 explains how a MIPS instruction is encoded in a binary number. Each column contains instruction encodings for a field (a contiguous group of bits) from an instruction. The numbers at the left margin are values for a field. For example, the `j` opcode has a value of 2 in the opcode field. The text at the top of a column names a field and specifies which bits it occupies in an instruction. For example, the `op` field is contained in bits 26–31 of an instruction. This field encodes most instructions. However, some groups of instructions use additional fields to distinguish related instructions. For example, the different floating-point instructions are specified by bits 0–5. The arrows from the first column show which opcodes use these additional fields.

## Instruction Format

The rest of this appendix describes both the instructions implemented by actual MIPS hardware and the pseudoinstructions provided by the MIPS assembler. The two types of instructions are easily distinguished. Actual instructions depict the fields in their binary representation. For example, in

Addition (with overflow)

```
add rd, rs, rt
```

0	rs	rt	rd	0	0x20
6	5	5	5	5	6

the `add` instruction consists of six fields. Each field's size in bits is the small number below the field. This instruction begins with 6 bits of 0s. Register specifiers begin with an  $r$ , so the next field is a 5-bit register specifier called `rs`. This is the same register that is the second argument in the symbolic assembly at the left of this line. Another common field is `imm16`, which is a 16-bit immediate number.

Pseudoinstructions follow roughly the same conventions, but omit instruction encoding information. For example:

Multiply (without overflow)

```
mul rdest, rsrc1, src2 pseudoinstruction
```

In pseudoinstructions, `rdest` and `rsrc` are registers and `src2` is either a register or an immediate value. In general, the assembler and SPIM translate a more general form of an instruction (e.g., `add $v1, $a0, 0x55`) to a specialized form (e.g., `addi $v1, $a0, 0x55`).

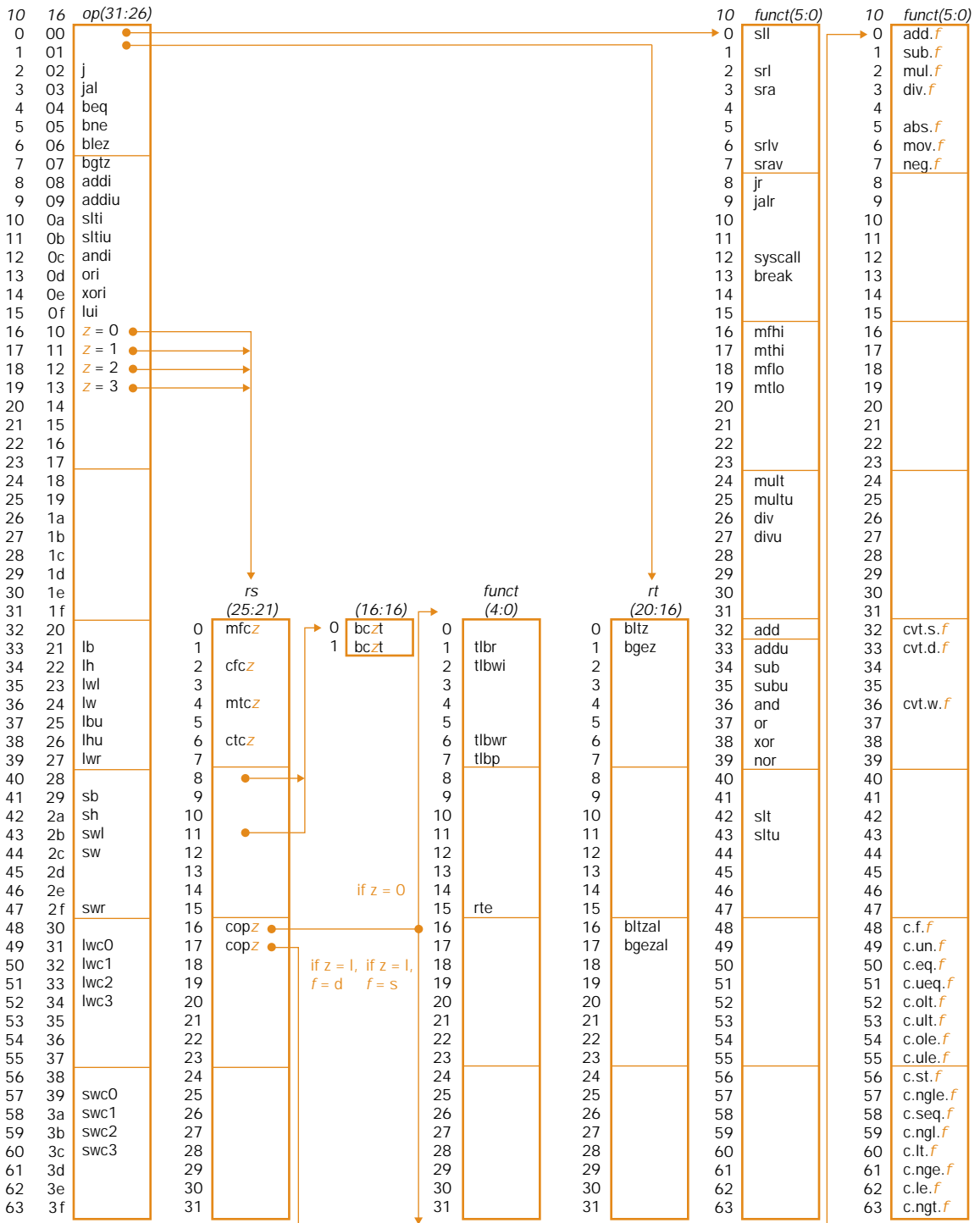

FIGURE A.19 MIPS opcode map. The values of each field are shown to its left. The first column shows the values in base 10 and the second shows base 16 for the op field (bits 31 to 26) in the third column. This op field completely specifies the MIPS operation except for 6 op values: 0, 1, 16, 17, 18, and 19. These operations are determined by other fields, identified by pointers. The last field (funct) uses “f” to mean “s” if rs = 16 and op = 17 or “d” if rs = 17 and op = 17. The second field (rs) uses “z” to mean “0”, “1”, “2”, or “3” if op = 16, 17, 18, or 19, respectively. If rs = 16, the operation is specified elsewhere: if z = 0, the operations are specified in the fourth field (bits 4 to 0); if z = 1, then the operations are in the last field with f = s. If rs = 17 and z = 1, then the operations are in the last field with f = d.

(page A-54)

## Arithmetic and Logical Instructions

Absolute value

abs rdest, rsrc *pseudoinstruction*

Put the absolute value of register rsrc in register rdest.

Addition (with overflow)

add rd, rs, rt

0	rs	rt	rd	0	0x20
6	5	5	5	5	6

Addition (without overflow)

addu rd, rs, rt

0	rs	rt	rd	0	0x21
6	5	5	5	5	6

Put the sum of registers rs and rt into register rd.

Addition immediate (with overflow)

addi rt, rs, imm

8	rs	rt	imm
6	5	5	16

Addition immediate (without overflow)

addiu rt, rs, imm

9	rs	rt	imm
6	5	5	16

Put the sum of register rs and the sign-extended immediate into register rt.

AND

and rd, rs, rt

0	rs	rt	rd	0	0x24
6	5	5	5	5	6

Put the logical AND of registers rs and rt into register rd.

AND immediate

andi rt, rs, imm

0xc	rs	rt	imm
6	5	5	16

Put the logical AND of register rs and the zero-extended immediate into register rt.

Divide (with overflow)

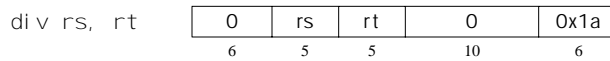

Divide (without overflow)

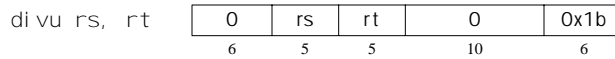

**Divide register `rs` by register `rt`. Leave the quotient in register `lo` and the remainder in register `hi`. Note that if an operand is negative, the remainder is unspecified by the MIPS architecture and depends on the convention of the machine on which SPIM is run.**

Divide (with overflow)

`div rdest, rsrc1, src2`      *pseudoinstruction*

Divide (without overflow)

`divu rdest, rsrc1, src2`      *pseudoinstruction*

**Put the quotient of register `rsrc1` and `src2` into register `rdest`.**

Multiply

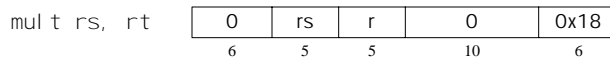

Unsigned multiply

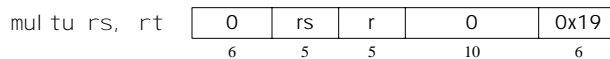

**Multiply registers `rs` and `rt`. Leave the low-order word of the product in register `lo` and the high-order word in register `hi`.**

Multiply (without overflow)

`mul rdest, rsrc1, src2`      *pseudoinstruction*

Multiply (with overflow)

`mulo rdest, rsrc1, src2`      *pseudoinstruction*

Unsigned multiply (with overflow)

`mul ou rdest, rsrc1, src2` *pseudoinstruction*

**Put the product of register `rsrc1` and `src2` into register `rdest`.**

Negate value (with overflow)

`neg rdest, rsrc` *pseudoinstruction*

Negate value (without overflow)

`negu rdest, rsrc` *pseudoinstruction*

**Put the negative of register `rsrc` into register `rdest`.**

NOR

`nor rd, rs, rt`

0	rs	rt	rd	0	0x27
6	5	5	5	5	6

**Put the logical NOR of registers `rs` and `rt` into register `rd`.**

NOT

`not rdest, rsrc` *pseudoinstruction*

**Put the bitwise logical negation of register `rsrc` into register `rdest`.**

OR

`or rd, rs, rt`

0	rs	rt	rd	0	0x25
6	5	5	5	5	6

**Put the logical OR of registers `rs` and `rd` into register `rt`.**

OR immediate

`ori rt, rs, imm`

0xd	rs	rt	imm
6	5	5	16

**Put the logical OR of register `rs` and the zero-extended immediate into register `rt`.**

Remainder

`rem rdest, rsrc1, rsrc2` *pseudoinstruction*



Unsigned remainder

remu rdest, rsrc1, rsrc2 *pseudoinstruction*

Put the remainder of register rsrc1 divided by register rsrc2 into register rdest. Note that if an operand is negative, the remainder is unspecified by the MIPS architecture and depends on the convention of the machine on which SPIM is run.

Shift left logical

sll rd, rt, shamt

0	rs	rt	rd	shamt	0
6	5	5	5	5	6

Shift left logical variable

sllv rd, rt, rs

0	rs	rt	rd	0	4
6	5	5	5	5	6

Shift right arithmetic

sra rd, rt, shamt

0	Rs	Rt	Rd	shamt	3
6	5	5	5	5	6

Shift right arithmetic variable

srav rd, rt, rs

0	rs	rt	rd	0	7
6	5	5	5	5	6

Shift right logical

srl rd, rt, shamt

0	rs	rt	rd	shamt	2
6	5	5	5	5	6

Shift right logical variable

srlv rd, rt, rs

0	rs	rt	rd	0	6
6	5	5	5	5	6

Shift register rt left (right) by the distance indicated by immediate sa or the register rs and put the result in register rd.

Rotate left

rol rdest, rsrc1, rsrc2 *pseudoinstruction*

Rotate right

`ror rdest, rsrc1, rsrc2` *pseudoinstruction*

**Rotate register `rsrc1` left (right) by the distance indicated by `rsrc2` and put the result in register `rdest`.**

Subtract (with overflow)

`sub rd, rs, rt`

0	rs	rt	rd	0	0x22
6	5	5	5	5	6

Subtract (without overflow)

`subu rd, rs, rt`

0	rs	rt	rd	0	0x23
6	5	5	5	5	6

**Put the difference of registers `rs` and `rt` into register `rd`.**

Exclusive OR

`xor rd, rs, rt`

0	rs	rt	rd	0	0x26
6	5	5	5	5	6

**Put the logical XOR of registers `rs` and `rt` into register `rd`.**

XOR immediate

`xori rt, rs, imm`

0xe	rs	rt	imm
6	5	5	16

**Put the logical XOR of register `rs` and the zero-extended immediate into register `rt`.**

## Constant-Manipulating Instructions

Load upper immediate

`lui rt, imm`

0xf	0	rt	imm
6	5	5	16

**Load the lower halfword of the immediate `imm` into the upper halfword of register `rt`. The lower bits of the register are set to 0.**

Load immediate

`li rdest, imm` *pseudoinstruction*

**Move the immediate `imm` into register `rdest`.**

## Comparison Instructions

Set less than

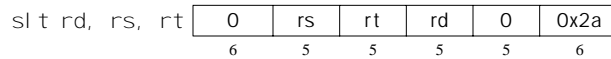

Set less than unsigned

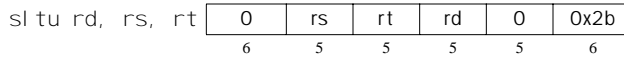

**Set register rd to 1 if register rs is less than rt, and to 0 otherwise.**

Set less than immediate

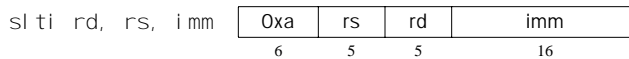

Set less than unsigned immediate

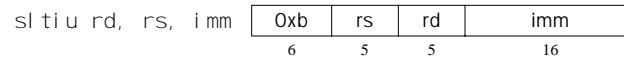

**Set register rd to 1 if register rs is less than the sign-extended immediate, and to 0 otherwise.**

Set equal

seq rdest, rsrc1, rsrc2 *pseudoinstruction*

**Set register rdest to 1 if register rsrc1 equals rsrc2, and to 0 otherwise.**

Set greater than equal

sge rdest, rsrc1, rsrc2 *pseudoinstruction*

Set greater than equal unsigned

sgeu rdest, rsrc1, rsrc2 *pseudoinstruction*

**Set register rdest to 1 if register rsrc1 is greater than or equal to rsrc2, and to 0 otherwise.**

Set greater than

sgt rdest, rsrc1, rsrc2      *pseudoinstruction*

Set greater than unsigned

sgtu rdest, rsrc1, rsrc2      *pseudoinstruction*

**Set register rdest to 1 if register rsrc1 is greater than rsrc2, and to 0 otherwise.**

Set less than equal

sle rdest, rsrc1, rsrc2      *pseudoinstruction*

Set less than equal unsigned

sleu rdest, rsrc1, rsrc2      *pseudoinstruction*

**Set register rdest to 1 if register rsrc1 is less than or equal to rsrc2, and to 0 otherwise.**

Set not equal

sne rdest, rsrc1, rsrc2      *pseudoinstruction*

**Set register rdest to 1 if register rsrc1 is not equal to rsrc2, and to 0 otherwise.**

## Branch Instructions

Branch instructions use a signed 16-bit instruction *offset* field; hence they can jump  $2^{15} - 1$  *instructions* (not bytes) forward or  $2^{15}$  instructions backwards. The *jump* instruction contains a 26-bit address field.

In the descriptions below, the offsets are not specified. Instead, the instructions branch to a label. This is the form used in most assembly language programs because the distance between instructions is difficult to calculate when pseudoinstructions expand into several real instructions.

Branch instruction

b label      *pseudoinstruction*

**Unconditionally branch to the instruction at the label.**

Branch coprocessor z true

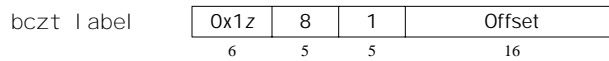

Branch coprocessor z false

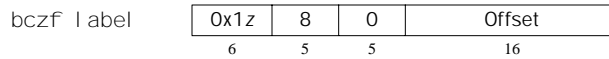

Conditionally branch the number of instructions specified by the offset if z's condition flag is true (false). z is 0, 1, 2, or 3. The floating-point unit is z = 1.

Branch on equal

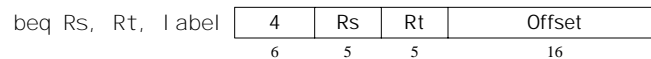

Conditionally branch the number of instructions specified by the offset if register rs equals rt.

Branch on greater than equal zero

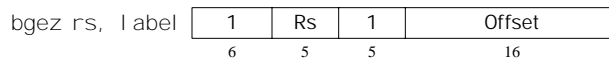

Conditionally branch the number of instructions specified by the offset if register rs is greater than or equal to 0.

Branch on greater than equal zero and link

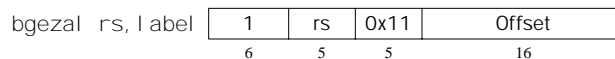

Conditionally branch the number of instructions specified by the offset if register rs is greater than or equal to 0. Save the address of the next instruction in register 31.

Branch on greater than zero

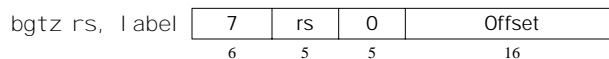

Conditionally branch the number of instructions specified by the offset if register rs is greater than 0.

Branch on less than equal zero

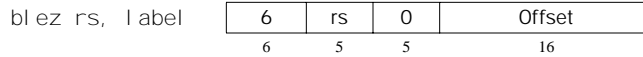

**Conditionally branch the number of instructions specified by the offset if register *rs* is less than or equal to 0.**

Branch on less than and link

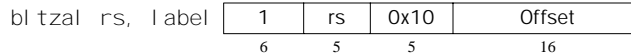

**Conditionally branch the number of instructions specified by the offset if register *rs* is less than 0. Save the address of the next instruction in register 31.**

Branch on less than zero

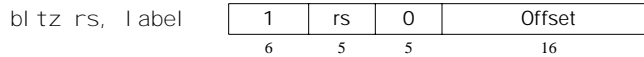

**Conditionally branch the number of instructions specified by the offset if register *rs* is less than 0.**

Branch on not equal

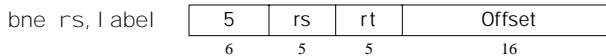

**Conditionally branch the number of instructions specified by the offset if register *rs* is not equal to *rt*.**

Branch on equal zero

beqz rsrc, label *pseudoinstruction*

**Conditionally branch to the instruction at the label if *rsrc1* equals 0.**

Branch on greater than equal

bge rsrc1, rsrc2, label *pseudoinstruction*

Branch on greater than equal unsigned

bgeu rsrc1, rsrc2, label *pseudoinstruction*

**Conditionally branch to the instruction at the label if register *rsrc1* is greater than or equal to *rsrc2*.**

Branch on greater than

bgt rsrc1, src2, label *pseudoinstruction*

Branch on greater than unsigned

bgtu rsrc1, rrc2, label *pseudoinstruction*

**Conditionally branch to the instruction at the label if register rsrc1 is greater than src2.**

Branch on less than equal

ble rsrc1, src2, label *pseudoinstruction*

Branch on less than equal unsigned

bleu rsrc1, src2, label *pseudoinstruction*

**Conditionally branch to the instruction at the label if register rsrc1 is less than or equal to src2.**

Branch on less than

blt rsrc1, rsrc2, label *pseudoinstruction*

Branch on less than unsigned

bltu rsrc1, rsrc2, label *pseudoinstruction*

**Conditionally branch to the instruction at the label if register rsrc1 is less than rsrc2.**

Branch on not equal zero

bnez rsrc, label *pseudoinstruction*

**Conditionally branch to the instruction at the label if register rsrc is not equal to 0.**

## Jump Instructions

Jump

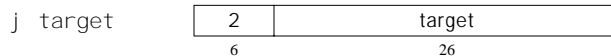

Unconditionally jump to the instruction at target.

Jump and link



Unconditionally jump to the instruction at target. Save the address of the next instruction in register *rd*.

Jump and link register

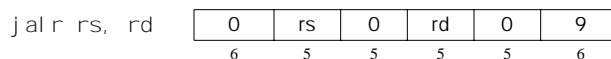

Unconditionally jump to the instruction whose address is in register *rs*. Save the address of the next instruction in register *rd* (which defaults to 31).

Jump register

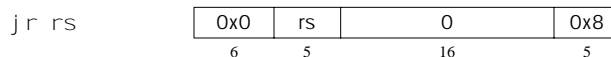

Unconditionally jump to the instruction whose address is in register *rs*.

## Load Instructions

Load address

l a rdest, address *pseudoinstruction*

Load computed *address*—not the contents of the location—into register *rdest*.

Load byte

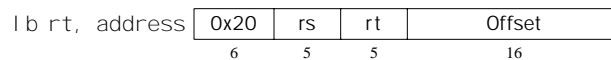



Load unsigned byte

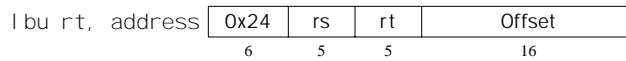

Load the byte at *address* into register *rt*. The byte is sign-extended by *l* b, but not by *l* bu.

Load halfword

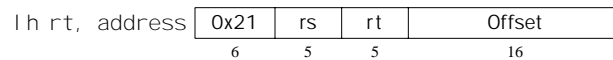

Load unsigned halfword

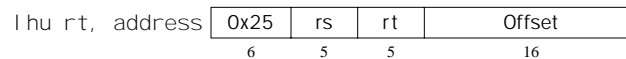

Load the 16-bit quantity (halfword) at *address* into register *rt*. The halfword is sign-extended by *l* h, but not by *l* hu.

Load word

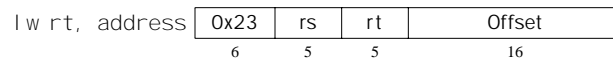

Load the 32-bit quantity (word) at *address* into register *rt*.

Load word coprocessor

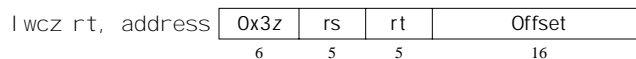

Load the word at *address* into register *rt* of coprocessor *z* (0–3). The floating-point unit is *z* = 1.

Load word left

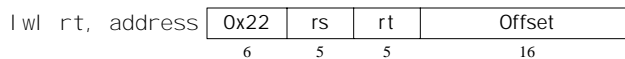

Load word right

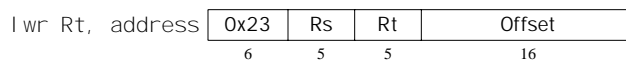

Load the left (right) bytes from the word at the possibly unaligned *address* into register *rt*.

Load doubleword

ld rdest, address *pseudoinstruction*

**Load the 64-bit quantity at *address* into registers *rdest* and *rdest + 1*.**

Unaligned load halfword

ulh rdest, address *pseudoinstruction*

Unaligned load halfword unsigned

ulhu rdest, address *pseudoinstruction*

**Load the 16-bit quantity (halfword) at the possibly unaligned *address* into register *rdest*. The halfword is sign-extended by *ulh*, but not *ulhu*.**

Unaligned load word

ulw rdest, address *pseudoinstruction*

**Load the 32-bit quantity (word) at the possibly unaligned *address* into register *rdest*.**

## Store Instructions

Store byte

sb rt, address

0x28	rs	rt	Offset
6	5	5	16

**Store the low byte from register *rt* at *address*.**

\_\_\_\_\_

Store halfword

sh rt, address

0x29	rs	rt	Offset
6	5	5	16

**Store the low halfword from register *rt* at *address*.**

\_\_\_\_\_

Store word

sw rt, address

0x2b	rs	rt	Offset
6	5	5	16

**Store the word from register *rt* at *address*.**

Store word coprocessor

swcz rt, address 

0x3(1-z)	rs	rt	Offset
6	5	5	16

**Store the word from register *rt* of coprocessor *z* at *address*. The floating point unit is  $z = 1$ .**

Store word left

swl rt, address 

0x2a	rs	rt	Offset
6	5	5	16

Store word right

swr rt, address 

0x2e	rs	rt	Offset
6	5	5	16

**Store the left (right) bytes from register *rt* at the possibly unaligned *address*.**

Store doubleword

sd rsrc, address *pseudoinstruction*

**Store the 64-bit quantity in registers *rsrc* and  $rsrc + 1$  at *address*.**

Unaligned store halfword

ush rsrc, address *pseudoinstruction*

**Store the low halfword from register *rsrc* at the possibly unaligned *address*.**

Unaligned store word

usw rsrc, address *pseudoinstruction*

**Store the word from register *rsrc* at the possibly unaligned *address*.**

## Data Movement Instructions

Move

move rdest, rsrc *pseudoinstruction*

**Move register *rsrc* to *rdest*.**

Move from hi

mFhi rd 

0	0	rd	0	0x10
6	10	5	5	6

Move from lo

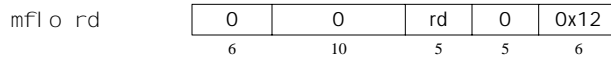

The multiply and divide unit produces its result in two additional registers, hi and lo. These instructions move values to and from these registers. The multiply, divide, and remainder pseudoinstructions that make this unit appear to operate on the general registers move the result after the computation finishes.

Move the hi (lo) register to register rd.

Move to hi

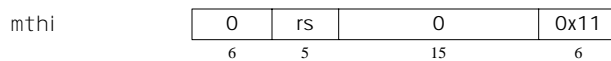

Move to lo

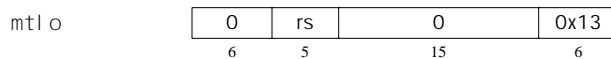

Move register Rs to the hi (lo) register.

Move from coprocessor z

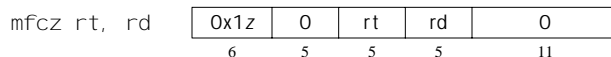

Coprocessors have their own register sets. These instructions move values between these registers and the CPU's registers.

Move coprocessor z's register rd to CPU register rt. The floating-point unit is coprocessor z = 1.

Move double from coprocessor 1

mfc1.d rdest, frsrc1 *pseudoinstruction*

Move floating-point registers frsrc1 and frsrc1 + 1 to CPU registers rdest and rdest + 1.

Move to coprocessor z

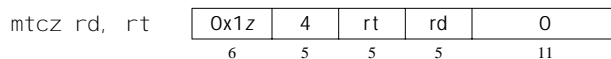

Move CPU register rt to coprocessor z's register rd.

## Floating-Point Instructions

The MIPS has a floating-point coprocessor (numbered 1) that operates on single precision (32-bit) and double precision (64-bit) floating-point numbers. This coprocessor has its own registers, which are numbered \$f0-\$f31. Because these registers are only 32 bits wide, two of them are required to hold doubles, so only floating-point registers with even numbers can hold double precision values.

Values are moved in or out of these registers one word (32 bits) at a time by `lwc1`, `swc1`, `mtc1`, and `mfc1` instructions described above or by the `l.s`, `l.d`, `s.s`, and `s.d` pseudoinstructions described below. The flag set by floating-point comparison operations is read by the CPU with its `bc1t` and `bc1f` instructions.

In the actual instructions below, bits 21–26 are 0 for single precision and 1 for double precision. In the pseudoinstructions below, `fdest` is a floating-point register (e.g., \$f2).

Floating-point absolute value double

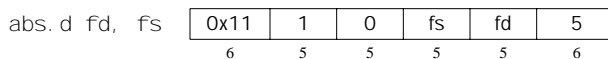

Floating-point absolute value single

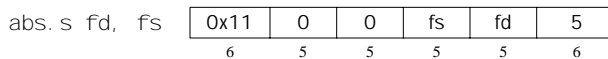

Compute the absolute value of the floating-point double (single) in register `fs` and put it in register `fd`.

\_\_\_\_\_

Floating-point addition double

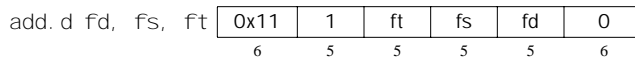

Floating-point addition single

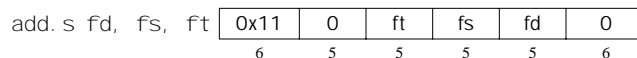

Compute the sum of the floating-point doubles (singles) in registers `fs` and `ft` and put it in register `fd`.

\_\_\_\_\_

Compare equal double

c. eq. d fs, ft	0x11	1	ft	fs	fd	FC	2
	6	5	5	5	5	2	4

Compare equal single

c. eq. s fs, ft	0x11	0	ft	fs	fd	FC	2
	6	5	5	5	5	2	4

**Compare the floating-point double in register `fs` against the one in `ft` and set the floating-point condition flag true if they are equal. Use the `bc1t` or `bc1f` instructions to test the value of this flag.**

Compare less than equal double

c. l.e. d fs, ft	0x11	1	ft	fs	0	FC	2
	6	5	5	5	5	2	4

Compare less than equal single

c. l.e. s fs, ft	0x11	0	ft	fs	0	FC	2
	6	5	5	5	5	2	4

**Compare the floating-point double in register `fs` against the one in `ft` and set the floating-point condition flag true if the first is less than or equal to the second. Use the `bc1t` or `bc1f` instructions to test the value of this flag.**

Compare less than double

c. l.t. d fs, ft	0x11	1	ft	fs	0	FC	0xc
	6	5	5	5	5	2	4

Compare less than single

c. l.t. s fs, ft	0x11	0	ft	fs	0	FC	0xc
	6	5	5	5	5	2	4

**Compare the floating-point double in register `fs` against the one in `ft` and set the condition flag true if the first is less than the second. Use the `bc1t` or `bc1f` instructions to test the value of this flag.**

Convert single to double

cvt. d. s fd, fs	0x11	1	0	fs	fd	0x21	
	6	5	5	5	5	6	

Convert integer to double

cv<sub>t</sub>.d.w fd, fs

0x11	0	0	fs	fd	0x21
6	5	5	5	5	6

**Convert the single precision floating-point number or integer in register fs to a double precision number and put it in register fd.**

Convert double to single

cv<sub>t</sub>.s.d fd, fs

0x11	1	0	Fs	Fd	0x20
6	5	5	5	5	6

Convert integer to single

cv<sub>t</sub>.s.w fd, fs

0x11	0	0	fs	fd	0x20
6	5	5	5	5	6

**Convert the double precision floating-point number or integer in register fs to a single precision number and put it in register fd.**

Convert double to integer

cv<sub>t</sub>.w.d fd, fs

0x11	1	0	fs	fd	0x24
6	5	5	5	5	6

Convert single to integer

cv<sub>t</sub>.w.s fd, fs

0x11	0	0	fs	fd	0x24
6	5	5	5	5	6

**Convert the double or single precision floating-point number in register fs to an integer and put it in register fd.**

Floating-point divide double

di.v.d fd, fs, ft

0x11	1	ft	fs	fd	3
6	5	5	5	5	6

Floating-point divide single

di.v.s fd, fs, ft

0x11	0	ft	fs	fd	3
6	5	5	5	5	6

**Compute the quotient of the floating-point doubles (singles) in registers fs and ft and put it in register fd.**

Load floating-point double

`l.d fdest, address` *pseudoinstruction*

Load floating-point single

`l.s fdest, address` *pseudoinstruction*

**Load the floating-point double (single) at address into register fdest.**

Move floating-point double

`mov.d fd, fs`

0x11	1	0	fs	fd	6
6	5	5	5	5	6

Move floating-point single

`mov.s fd, fs`

0x11	0	0	fs	fd	6
6	5	5	5	5	6

**Move the floating-point double (single) from register fs to register fd.**

Floating-point multiply double

`mul.d fd, fs, ft`

0x11	1	ft	fs	fd	2
6	5	5	5	5	6

Floating-point multiply single

`mul.s fd, fs, ft`

0x11	0	ft	fs	fd	2
6	5	5	5	5	6

**Compute the product of the floating-point doubles (singles) in registers fs and ft and put it in register fd.**

Negate double

`neg.d fd, fs`

0x11	1	ft	fs	fd	7
6	5	5	5	5	6

Negate single

`neg.s fd, fs`

0x11	0	ft	fs	fd	7
6	5	5	5	5	6

**Negate the floating-point double (single) in register fs and put it in register fd.**



Store floating-point double

s.d fdest, address *pseudoinstruction*

Store floating-point single

s.s fdest, address *pseudoinstruction*

**Store the floating-point double (single) in register dest at address.**

Floating-point subtract double

sub.d fd, fs, ft

0x11	1	ft	fs	fd	1
6	5	5	5	5	6

Floating-point subtract single

sub.s fd, fs, ft

0x11	0	ft	fs	fd	1
6	5	5	5	5	6

**Compute the difference of the floating-point doubles (singles) in registers fs and ft and put it in register fd.**

## Exception and Interrupt Instructions

Return from exception

rfe

0x10	1	0	0x20
6	1	19	6

**Restore the Status register.**

System call

syscall

0	0	0xc
6	20	6

**Register \$v0 contains the number of the system call (see Figure A.17) provided by SPIM.**

Break

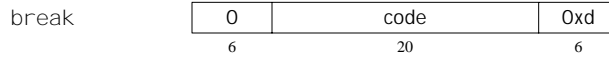

Cause exception *code*. Exception 1 is reserved for the debugger.

No operation

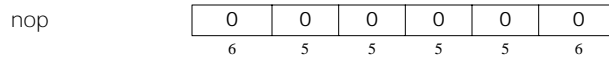

Do nothing.

## A.11

## Concluding Remarks

Programming in assembly language requires a programmer to trade off helpful features of high-level languages—such as data structures, type checking, and control constructs—for complete control over the instructions that a computer executes. External constraints on some applications, such as response time or program size, require a programmer to pay close attention to every instruction. However, the cost of this level of attention is assembly language programs that are longer, more time-consuming to write, and more difficult to maintain than high-level language programs.

Moreover, three trends are reducing the need to write programs in assembly language. The first trend is toward the improvement of compilers. Modern compilers produce code that is typically comparable to the best handwritten code and is sometimes better. The second trend is the introduction of new processors that are not only faster, but in the case of processors that execute multiple instructions simultaneously, also more difficult to program by hand. In addition, the rapid evolution of the modern computer favors high-level language programs that are not tied to a single architecture. Finally, we witness a trend toward increasingly complex applications—characterized by complex graphic interfaces and many more features than their predecessors. Large applications are written by teams of programmers and require the modularity and semantic checking features provided by high-level languages.

### To Probe Further

Kane, G., and J. Heinrich [1992]. *MIPS RISC Architecture*, Prentice Hall, Englewood Cliffs, NJ.  
*The last word on the MIPS instruction set and assembly language programming on these machines.*

Aho, A., R. Sethi, and J. Ullman [1985]. *Compilers: Principles, Techniques, and Tools*, Addison-Wesley, Reading, MA.

*Slightly dated and lacking in coverage of modern architectures, but still the standard reference on compilers.*

## A.12

## Key Terms

A number of key terms have been introduced in this appendix. Check the Glossary for definitions of terms you are uncertain of.

absolute address	interrupt handler	separate compilation
assembler directive	local label	source language
backpatching	machine language	stack segment
callee-saved register	macros	static data
caller-saved register	procedure call or stack frame	symbol table
data segment	recursive procedures	text segment
external or global label	register-use or procedure-call convention	unresolved reference
formal parameter	relocation information	virtual machine
forward reference		

## A.13

## Exercises

A.1 [5] <§A.5> Section A.5 described how memory is partitioned on most MIPS systems. Propose another way of dividing memory that meets the same goals.

A.2 [20] <§A.6> Rewrite the code for `fact` to use fewer instructions.

A.3 [5] <§A.7> Is it ever safe for a user program to use registers `$k0` or `$k1`?

A.4 [25] <§A.7> Section A.7 contains code for a very simple exception handler. One serious problem with this handler is that it disables interrupts for a long time. This means that interrupts from a fast I/O device may be lost. Write a better exception handler that is interruptible and enables interrupts as quickly as possible.

A.5 [15] <§A.7> The simple exception handler always jumps back to the instruction following the exception. This works fine unless the instruction that causes the exception is in the delay slot of a branch. In that case, the next instruction is the target of the branch. Write a better handler that uses the EPC register to determine which instruction should be executed after the exception.

A.6 [5] <§A.9> Using SPIM, write and test an adding machine program that repeatedly reads in integers and adds them into a running sum. The program should stop when it gets an input that is 0, printing out the sum at that point. Use the SPIM system calls described on pages A-48 and A-49.

A.7 [5] <§A.9> Using SPIM, write and test a program that reads in three integers and prints out the sum of the largest two of the three. Use the SPIM system calls described on pages A-48 and A-49. You can break ties arbitrarily.

A.8 [5] <§A.9> Using SPIM, write and test a program that reads in a positive integer using the SPIM system calls. If the integer is not positive, the program should terminate with the message “Invalid Entry”; otherwise the program should print out the names of the digits of the integers, delimited by exactly one space. For example, if the user entered “728,” the output would be “Seven Two Eight.”

A.9 [25] <§A.9> Write and test a MIPS assembly language program to compute and print the first 100 prime numbers. A number  $n$  is prime if no numbers except 1 and  $n$  divide it evenly. You should implement two routines:

- `test_prime (n)` Return 1 if  $n$  is prime and 0 if  $n$  is not prime.
- `main ()` Iterate over the integers, testing if each is prime. Print the first 100 numbers that are prime.

Test your programs by running them on SPIM.

A.10 A.10 [10] <§§A.6, A.9> Using SPIM, write and test a recursive program for solving the classic mathematical recreation, the Towers of Hanoi puzzle. (This will require the use of stack frames to support recursion.) The puzzle consists of three pegs (1, 2, and 3) and  $n$  disks (the number  $n$  can vary; typical values might be in the range from 1 to 8). Disk 1 is smaller than disk 2, which is in turn smaller than disk 3, and so forth, with disk  $n$  being the largest. Initially, all the disks are on peg 1, starting with disk  $n$  on the bottom, disk  $n - 1$  on top of that, and so forth, up to disk 1 on the top. The goal is to move all the disks to peg 2. You may only move one disk at a time, that is, the top disk from any of the three pegs onto the top of either of the other two pegs. Moreover, there is a constraint: You must not place a larger disk on top of a smaller disk.

The C program on the next page can be used to help write your assembly language program.

```
/* move n smallest disks from start to finish using extra */
void hanoi (int n, int start, int finish, int extra){
    if(n != 0){
        hanoi (n-1, start, extra, finish);
        print_string(" Move di sk");
        print_int(n);
        print_string(" from peg");
        print_int(start);
        print_string(" to peg");
        print_int(finish);
        print_string(". \n");
        hanoi (n-1, extra, finish, start);
    }
}
main(){
    int n;
    print_string("Enter number of di sks>");
    n = read_int();
    hanoi (n, 1, 2, 3);
    return 0;
}
```

